



iClave

OPERATOR MANUAL

Rev. 06
Date: 06/2026
OM1019EN



This manual is applicable to

Model name	Prefix for identification	Extended description	REF
iClave 18	GCN	iClave 18 No Printer	91812B0100
iClave 18	GCP	iClave 18 Printer	91812B0100P
iClave 24	GDN	iClave 24 No printer	92412B0100
iClave 24	GDP	iClave 24 Printer	92412B0100P

1.	General Information	5
1.1	Purpose of the manual	5
1.2	Criteria for use of the manual and finding information	5
1.3	Professional user profiles	6
1.4	Conformity to European Directives.....	6
1.5	Warranty	7
2.	Safety information	8
2.1	General safety information	8
2.2	Safety and protection features on the device.....	9
2.2.1	Soft-close door with double safety	9
2.2.2	Overpressure protection - safety valve and pressure sensor	9
2.2.3	Blackout protection	9
2.2.4	Overheating Protection	9
2.2.5	Automatic power off	9
2.3	Safety signs on the device	10
2.4	Residual risks	11
2.5	Bacteriological risks	11
3.	Characteristics.....	12
3.1	Description of the sterilizer.....	12
3.2	Intended use.....	12
3.3	Environmental conditions.....	12
3.4	Units that make up the sterilizer.....	13
3.5	Components supplied with the sterilizer	15
3.6	Size and weight of package	16
3.7	Size and weight of sterilizer	16
3.8	Technical specifications.....	17
3.9	Labels and symbols.....	19
3.9.1	Labels present on the back of the sterilizer	19
3.9.2	Labels and symbols present on the packaging	19
3.9.3	Symbols legend	20
4.	Installation	23
4.1	Unpacking and transport.....	23
4.2	Positioning.....	24
4.3	Installation of rear spacers (optional)	25
4.4	Initial start-up.....	26
4.5	Home menu	28
4.6	Cycles menu.....	28
4.7	Test menu	28
4.8	Info menu.....	28
4.8.1	Device Messages	29
4.9	Settings menu.....	29
4.9.1	General settings	29
4.9.1.a	Change date/time and their format	29
4.9.1.b	Pressure and temperature unit modification	31
4.9.1.c	Performance modification	31
4.9.1.d	Language modification	32
4.9.1.e	Water Load Modification	32
4.9.1.f	Change the preferred cycles	32
4.9.1.g	change the screensaver clock type.....	32
4.9.2	Operator menu	33
4.9.2.a	Create a new operator.....	33
4.9.2.b	Modification of an existing operator.....	33
4.9.2.c	Delete an existing operator	33
4.9.3	Printers menu.....	34
4.9.3.a	Activation / Deactivation internal printer	34
4.9.3.b	Activation / Deactivation label printer	34
4.9.3.c	Reprint a report.....	34
4.9.3.d	Re-print the label.....	35
4.9.4	Connections menu	35
4.9.5	Archiviation report menu.....	35

4.9.5.a	Export report on usb insertion.....	35
4.9.5.b	Export report at the end of cycle	36
4.9.5.c	Format USB Stick	36
4.9.5.d	Export report.....	36
4.9.5.e	Export Logs.....	36
4.9.6	Maintenance menu	37
4.9.7	Technical menu.....	37
5.	Using the sterilizer	38
5.1	Turning the sterilizer on	38
5.2	Opening / closing the door.....	38
5.3	Tray arrangement and dimensions	39
5.4	Daily tests to check the sterilizer's performance	39
5.4.1	Vacuum test	40
5.4.2	B&D Helix test.....	40
5.5	Preparing the material before sterilization	40
5.5.1	Preliminary operations.....	40
5.6	Treatment of materials and instruments before sterilization	41
5.7	Arranging the material on the trays before sterilization.....	41
5.8	Program selection	43
5.8.1	Sterilization time modification	45
5.8.2	Drying time modification.....	45
5.8.3	Cycle start delay.....	45
5.9	Running a cycle.....	45
5.9.1	Pre-heating phase (1)	48
5.9.2	Pulses phase (2).....	48
5.9.3	Sterilization phase (3).....	48
5.9.4	Drying phase (4).....	48
5.9.5	End of cycle	49
5.10	Interrupting the programme	49
5.11	Topping up with demineralized water and draining contaminated water	50
5.11.1	Topping up the demineralized water tank.....	50
5.11.2	Draining the used water recovery tank	50
5.11.3	Checking the water quality.....	51
5.12	Peripheral devices.....	51
5.12.1	Internal printer (optional).....	51
5.12.2	External printer connection (optional).....	52
5.12.3	Archiving on a USB stick (optional).....	52
5.13	Web server.....	53
5.13.1	How to open the Web Server page.....	53
5.13.2	Device state.....	53
5.13.3	Download Data.....	54
5.13.4	How to set drying times.....	55
5.14	Cybersecurity	55
6.	Alarms	56
6.1	Generality	56
6.2	Informations list.....	56
6.3	Notification list	57
6.4	Alarms list	57
7.	Maintenance	59
7.1	Ordinary maintenance	59
7.1.1	Demineralized water filter replacement and cleaning	59
7.1.2	H2O chamber filter clean and replacement	60
7.1.3	Replacing the bacteriological filter	60
7.2	Scheduled maintenance.....	60
7.3	Periodic validation / requalification of the sterilization process.....	60
7.4	Fuses replacement.....	61
7.5	Useful life of the device	61
7.6	Hot and cold spot inside the chamber	61
8.	Disposal.....	62

1. General Information

1.1 Purpose of the manual

This operator manual was issued by NSK Dental Italy to provide the operator with the necessary information for:

- proper installation
- appropriate and safe use
- careful maintenance

The manual is an integral part of the iClave steam sterilizer, hereafter referred to in this manual as the “sterilizer” or, more simply, the “device”, and must always remain with it and be immediately available. It should always be kept close to the device, in an easily accessible place and protected from environmental agents that could affect its integrity and durability. It should be readily at hand for immediate consultation at any time by operators and maintainers.

Read the manual carefully and understand it fully before installing the device and putting it into service, particularly the instructions given in the chapter on “Safety information”, which are aimed at preventing potential risks that could cause injuries to the operator or damage to the device.

The company that uses the devices is responsible for always ensuring that all operators fully understand the operating instructions.

NSK Dental Italy declines any responsibility for failure to observe the safety and prevention rules described in the various sections of this manual and for damages caused by improper installation and use of the device.

All rights are reserved.

This publication may not be reproduced, transmitted, transcribed, stored in computer systems or translated into another language or computer language, even partially, in any form or by any means without prior written permission from NSK Dental Italy.

NSK Dental Italy reserves the right to make changes to the technical characteristics of the product described in this manual at any time, with no obligation of prior notice or communication.



1.2 Criteria for use of the manual and finding information

The information and instructions are collected and organized into chapters and paragraphs, and can be easily found by searching the index.

Information preceded by a warning sign must be read carefully.

Basic information for the health and safety of operators/maintenance personnel is contained in a box marked with warning signs on a coloured background, as illustrated below.

Safety instructions are classified as follows, in accordance with the seriousness of the risk:

Classification	Risk level
 NOTE	Information on general product specifications highlighted to prevent malfunctions and loss of product performance.
 CAUTION	Indicates cases where failure to follow the safety instructions may lead to minor or considerable injury to people or damage to the device.
 WARNING	Indicates cases where failure to follow the safety instructions may lead to serious injury to people or damage to the device.

1.3 Professional user profiles

European regulations on safety and the sterilization process describe the following professional roles:

OPERATOR: a person who uses the device for the intended purpose on a daily basis.

The operators who use the sterilizer daily are represented by qualified medical personnel:

- Doctor;
- Dental surgeon;
- Implantologist;
- Hygienist.
- Dental assistant

MAINTAINER: a person assigned to the ordinary maintenance of the device on a daily basis.

Note: the operator and maintenance technician may also be the same person.

TECHNICIAN: a person assigned to the extraordinary maintenance of the device. It is the person authorized to perform all electrical and mechanical interventions, adjustments and repairs.

RESPONSIBLE AUTHORITY: an individual (often the employer) or group of people responsible for the use and maintenance of the device, who ensures that:

- the operator and maintenance technician are adequately trained to use the device in full safety; the operator is adequately trained on hygiene and sterilization practices used in the dental field;
- regular training is provided for all personnel regarding the operation and maintenance of the device, including emergency procedures in the event of emission of toxic, flammable, explosive or pathogenic material into the environment;
- registration documents for attendance of the training are preserved and its full understanding is verified;
- a written, electronic or paper record is kept of the sterilization procedures carried out from the moment the device is installed.

Note: Any serious accident occurring with the device must be reported to the Manufacturer and to the competent authority of the Member State where the accident occurred.

Please report incidents, near misses and product malfunctions to the NSK Dental Italy customer care office at: servicesterilization@nsk-italy.it.

1.4 Conformity to European Directives

As reported in the declaration of conformity Mod.444-003, drawn up in compliance with Article 19 Annex IV of the regulation 2017/745/EU, the iClave sterilizer manufactured by NSK Dental Italy meets the essential requirements defined by 2017/745/EU Regulation for medical devices, according to which it is classified in class IIb. It also complies with the Directives 2014/68/EC for pressure vessels (PED), 2014/30/EU (Directive Electromagnetic Compatibility) and 2014/35/EU (Directive Low Voltage).

The iClave sterilizer also complies with the reference technical standards EN 13060, IEC 61010-1, IEC 61010-2-040 and IEC 61326-1.

The declaration of conformity is a printed accompanying document in paper format.

This NSK product has been designed and manufactured with high quality materials and parts that can be recycled and reused.



Separate disposal of electrical and electronic equipment, in accordance with Directive 2012/19/UE (WEEE/RAEE). The equipment belongs to Category 8 (medical equipment).



CE Mark and Notified Body number. The CE mark indicates that the device satisfies the essential requirements of the Medical Devices Regulatory (UE) 2017/745.

Notified Body: IMQ S.p.A. via Quintiliano 43, 20138 Milan (MI), Italy.

Identification N. 0051.

1.5 Warranty

NSK products are guaranteed against manufacturing errors and defective materials. NSK Dental Italy reserves the right to examine and determine the cause of any problem. The warranty will be void if the product has not been used properly or for its intended use, if it has been tampered with by unqualified personnel or fitted with non-original NSK Dental Italy parts. Replacement parts are available for ten years after production of the model has ceased.

Failure to follow the guidelines given below will void the warranty and/or make the device dangerous to operate.

- In the event of faults and/or malfunction, follow the guidelines given in paragraph 6.3 "Notification list" and paragraph 6.4 "Alarms list". If the problem persists, do not attempt to operate the device but contact the NSK Dental Italy technical support: NSK Dental Italy, Via dell'Agricoltura 21, 36016 Thiene (VI), email address: servicesterilization@nsk-italy.it
- Do not operate the device until the necessary repairs have been made to restore its proper operation.
- Do not attempt to disassemble the device, replace faulty or damaged components and/or have it adjusted or repaired by personnel without proper training and authorization from NSK Dental Italy.
- Faulty or damaged components should only be replaced with original NSK Dental Italy parts.

The warranty is valid for 24 months from the date of sale of the device for any manufacturing errors or material defects. The effective date of the guarantee is determined by the date of the invoice for the purchase of the appliance. NSK Dental Italy reserves the right to analyze and establish the cause of any problem.

The warranty does not cover:

- Damages related to normal wear, improper use, neglect, non-compliance with instructions for use
- Breakdowns due to natural disasters or fires;
- Damage due to improper interventions or repairs not authorized by NSK Dental Italy;
- Damage due to tampering by unqualified personnel;
- Anomalies deriving from parts or materials that are not original, therefore causes not attributable to the manufacturer.

The warranty is also void if:

- The equipment shows damages caused by falling, by exposure to flames or in any case by causes not linked to manufacturing defects;
- There was an incorrect installation;
- There has been an incorrect connection to the electrical network (wrong nominal power supply voltage);
- The serial number has been removed, erased or altered.

Please note that opening the equipment by personnel NOT AUTHORIZED by the manufacturer entails the expiry of the warranty rights and the RESPONSIBILITY of the CE certification.

2. Safety information

2.1 General safety information

To maintain a maximum level of device safety for patients and specialized professional operators, it is essential that:

- the operators and maintenance technicians have read and understood the instructions for installation and use of the device
- the periodic maintenance operations described in the chapter 7 "Maintenance" are carried out
- the following safety instructions are observed:



- Ensure that the device is connected to a power socket with a protective earth connection.
- Keep the plug in the socket until the sterilization is finished and do not use the socket for other devices at the same time.
- Use only original NSK Dental Italy power cables, as other cables can cause electric shock, fires or damage to the device.
- Do not turn the power on or off unless strictly necessary, as this may trip the fuse.
- Do not touch the power cord with wet hands as this may cause electric shock.
- Install the product with sufficient space to allow immediate removal of the electrical plug.
- Turn off the power switch and disconnect the power cord before performing any maintenance.
- Do not connect non-original NSK Dental Italy accessories or equipment to the device.
- Keep explosive substances and flammable materials far from the device.
- If the device overheats or emits a bad smell, turn off the power switch immediately, remove the plug from the electrical socket and contact technical support.
- Do not allow water or disinfectant liquid to enter the inside of the device as it may cause a short circuit and electrical shock.
- Avoid inadvertently touching the door or the area around the chamber while the device is in operation or immediately after stopping the product, as these reach high temperatures and can cause burns.
- Do not obstruct or cover the steam outlet on the product with other objects. In addition, avoid inadvertently placing your face or hands near the steam outlet, as this can cause burns.
- Only use NSK Dental Italy original components and spare parts.
- Use tape indicators to verify whether an item was successfully sterilised.



- The device must only be installed in enclosed environments.
- Install the machine on a flat surface.
- Do not sterilize liquids or objects other than medical instruments reported in the intended use.
- Avoid any impact on the device. Do not drop the device.
- Wash and dry objects before sterilization. Chemical detergent residues in the chamber can cause corrosion or leave bad odours on sterilized objects.
- Insert the objects to be sterilized using the racks. Directly inserting objects into the chamber may cause sterilization problems, discolouration or even damage to the objects.
- Ensure that any water has been drained before moving the device.
- Use a container or case for sterilizing fine-pointed objects, as these may protrude from the bottom of the rack.
- Sterilize the instruments in accordance with the parameters recommended by the manufacturer or retailer.
- If any irregularities are noticed during use, stop the sterilization cycle and contact technical support.
- Conduct periodic diagnostic checks and routine maintenance operations.
- If the device has not been used for a long time, check that it is working properly before use.
- Portable and mobile RF communication devices can interfere with the device.
- The device must not be used near or above another device. If this is not possible, ensure that all devices work properly.
- The device may malfunction if used near electromagnetic interference. Do not install the device near other equipment that emits magnetic waves. Turn off the power if an ultrasonic oscillation or electrosurgery device is located near the site of use.
- It is the responsibility of the user to fill the autoclave with clean demineralised water in compliance with the EN 13060 standard, free from contaminants and other pathogens.

2.2 Safety and protection features on the device

The sterilizer has several devices, listed below, that ensure the total safety of operators.

2.2.1 Soft-close door with double safety

An electromechanical device allows the door to be opened only under the following conditions:

- device plugged in and switched on
- no alarms activated
- internal pressure not hazardous to the operator (Ambient pressure ± 15 mbar)

For additional safety, the Unlock button on display must be pressed to unlock the door at the end of a cycle.

 If the device is switched off with the door open, do not try to close the door by forcing the handle. To close the door, simply turn the device on again using the main switch.

2.2.2 Overpressure protection - safety valve and pressure sensor

Safety valve

This is a valve located on the back of the device (fig.1) that is triggered when the pressure inside the chamber exceeds 2.6 bar. In the event that it is requested to verify the correct operation of the valve, switch the device off and allow it to cool down, pull it slightly until a "click" is heard and then check that it moves freely. The safety valve requires no adjustment or maintenance.

Pressure sensor

This is triggered when the pressure inside the sterilization chamber exceeds 2.4 bar; an acoustic signal alerts the operator and the message A75 appears on the display.

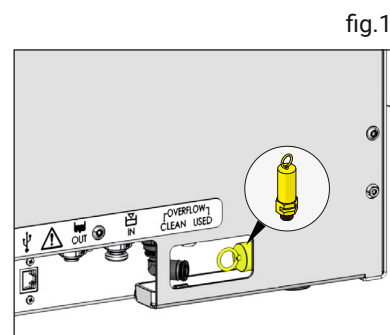

2.2.3 Blackout protection

In the event of a power supply failure during the sterilization cycle, the pressure in the chamber is completely released and brought down to ambience level. When the power supply returns, the message A70 appears on the display.

2.2.4 Overheating Protection

The temperature inside the sterilization chamber is programmed to not exceed a limit of 142 °C; in the event of failure, additional protection is provided to prevent the temperature from rising above 150 °C.

2.2.5 Automatic power off

Thirty minutes after the end of the cycle, unless the door has been opened or a button pressed on the front panel, the device automatically switches off.

 This function is not implemented if no sterilization cycle has been run.

2.3 Safety signs on the device

The following warning and hazard signs are located on the sterilizer in the positions indicated.

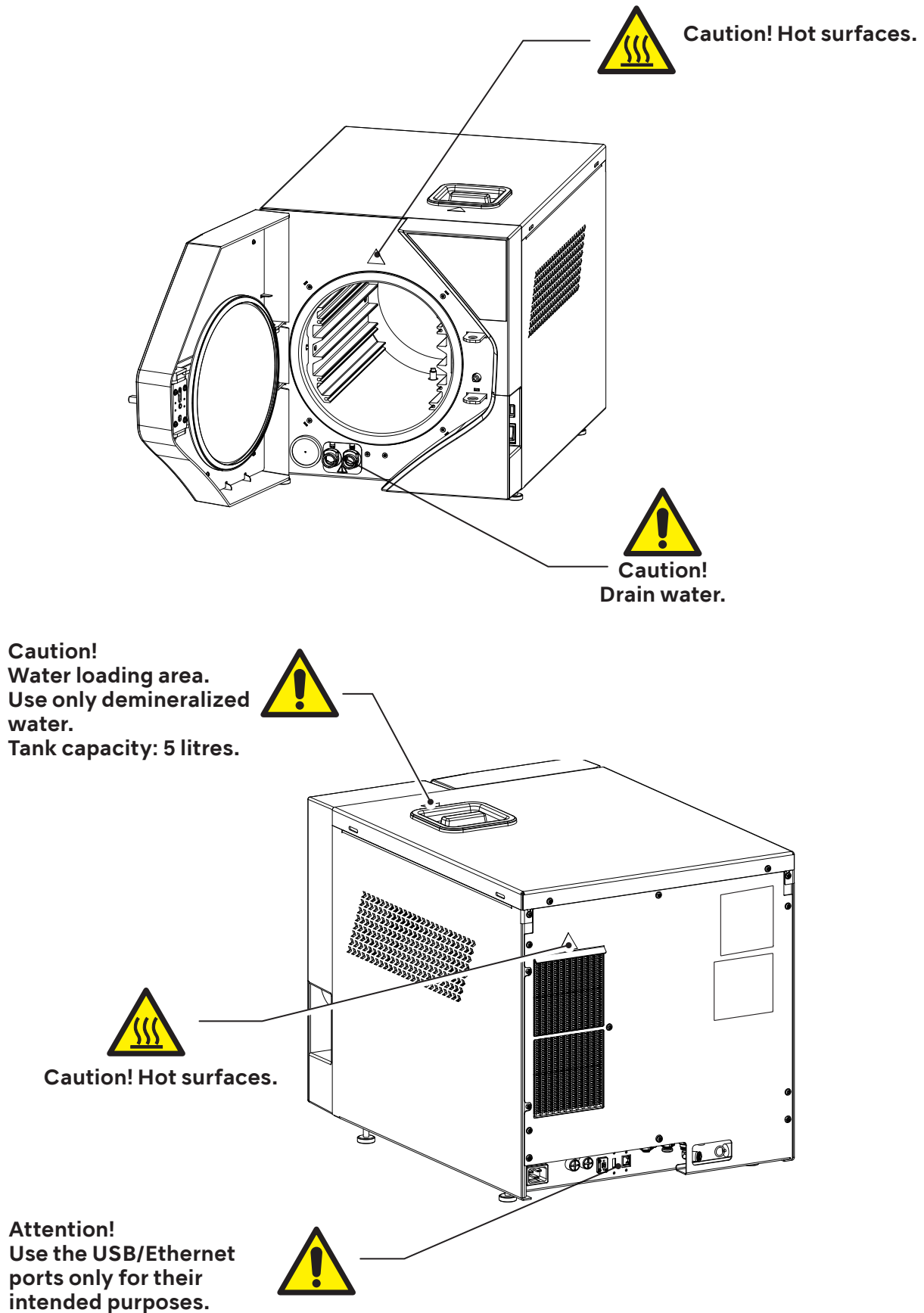

2.4 Residual risks

The sterilization process works by means of pressurized steam at high temperature. When removing a load from the sterilization chamber, always use suitable tools and personal protective equipment for handling the hot racks and tools.

When opening the sterilizer door, particularly during a cycle failure, a small quantity of steam or hot condensate may be released; open the door with caution.

 During normal daily use of the device, residual heat risks persist in the areas marked with special warning signs, as shown in the figure. Avoid direct contact of body parts with these surfaces.

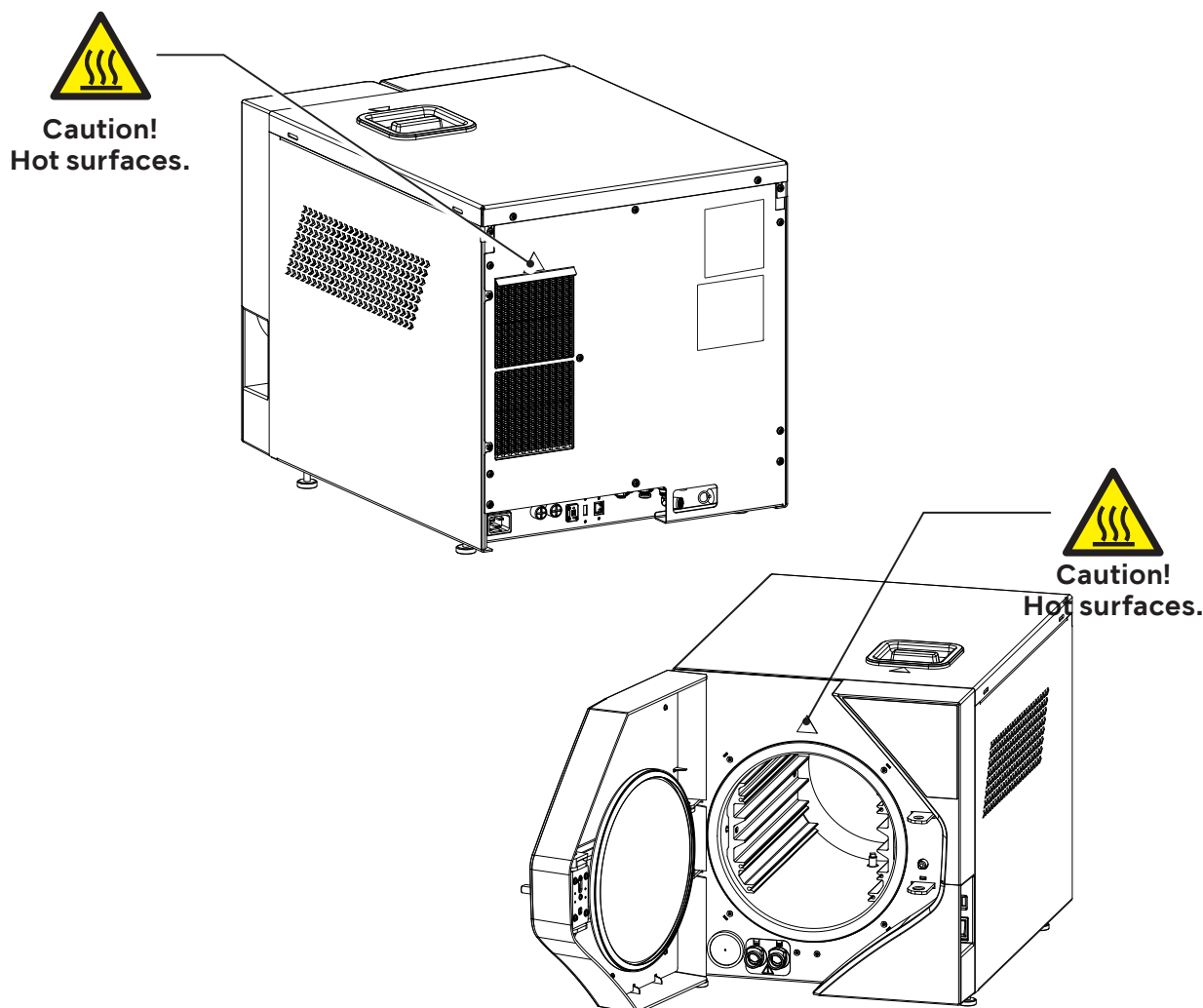

2.5 Bacteriological risks

- If the sterilization cycle is not completed, the load, the trays and their restraint system, as well as the inside of the chamber, should always be considered as potentially contaminated until a subsequent sterilization cycle has been successfully completed.
- The water in the recovery tank should be considered as contaminated, therefore necessary precaution should be taken when emptying the tank. Check the integrity of the drain hose before using it.
- To avoid cross-contamination, wear a new pair of sterile gloves for each task. Take particular care to replace the sterile gloves when loading or unloading instruments from the sterilization chamber and during maintenance operations.
- The use of contaminated water may involve residual risks. It is the responsibility of the user to fill the autoclave with clean demineralised water, free from contaminants and other pathogens. For the water quality see chapter 5.11.3 .

3. Characteristics

3.1 Description of the sterilizer

The iClave is a table-top steam sterilizer designed for the sterilization of dental and medical products and equipment, in accordance with the requirements of standard EN 13060.

It consists of an airtight stainless steel sterilization chamber accessed through a front door; it is protected by an external shock-resistant moulded plastic body and equipped with protective devices that allow operators to use it in full safety. The sterilization cycles are started from the operator touch-screen controlpanel on the front of the device, beside the door.

A detailed description of the units that make up the sterilizer and the components supplied is given in the following paragraphs.

3.2 Intended use

Small steam sterilizer used to sterilize medical devices or for materials that are likely to come into contact with blood or body fluids, according to requirements of EN 13060 it is suitable for following sterilization cycle types and loads:

Class B sterilization

Sterilization of solid products, porous products and lumen devices, wrapped or non-wrapped as represented by the test loads.

Class S sterilization

Sterilization of non-wrapped solid products.



Sterilizing instruments unsuitable for this process may expose the operator to risk, cause damage to the sterilizer and compromise its safety devices.
Always check the manufacturer's label to ensure that products are suitable for sterilization.
The device is not suitable for the sterilization of liquids and flammable materials.
Do not use the device in the presence of anaesthetic or flammable gases.



The room where the device is installed should be adequately ventilated to prevent excessive humidity. Any possible condensation is collected in the small drip tray.

3.3 Environmental conditions

The sterilizer is designed to operate in medical locations (e.g. Dental practices, dental and medical clinics, hospitals) with following environmental conditions:

- temperatures between 5°C and 40°C;
- maximum relative humidity of 80% with environmental temperature until 32°C and linearly decrease until 50% in case of environmental temperature until 40°C;
- air pressure between 750 mBar and 1050 mBar;
- altitude between 0 and +2000 meters above sea level.

Transport and storage conditions: temperature -10°C÷50°C, humidity without condensation 10÷95%, air pressure 50÷106 kPa.

3.4 Units that make up the sterilizer

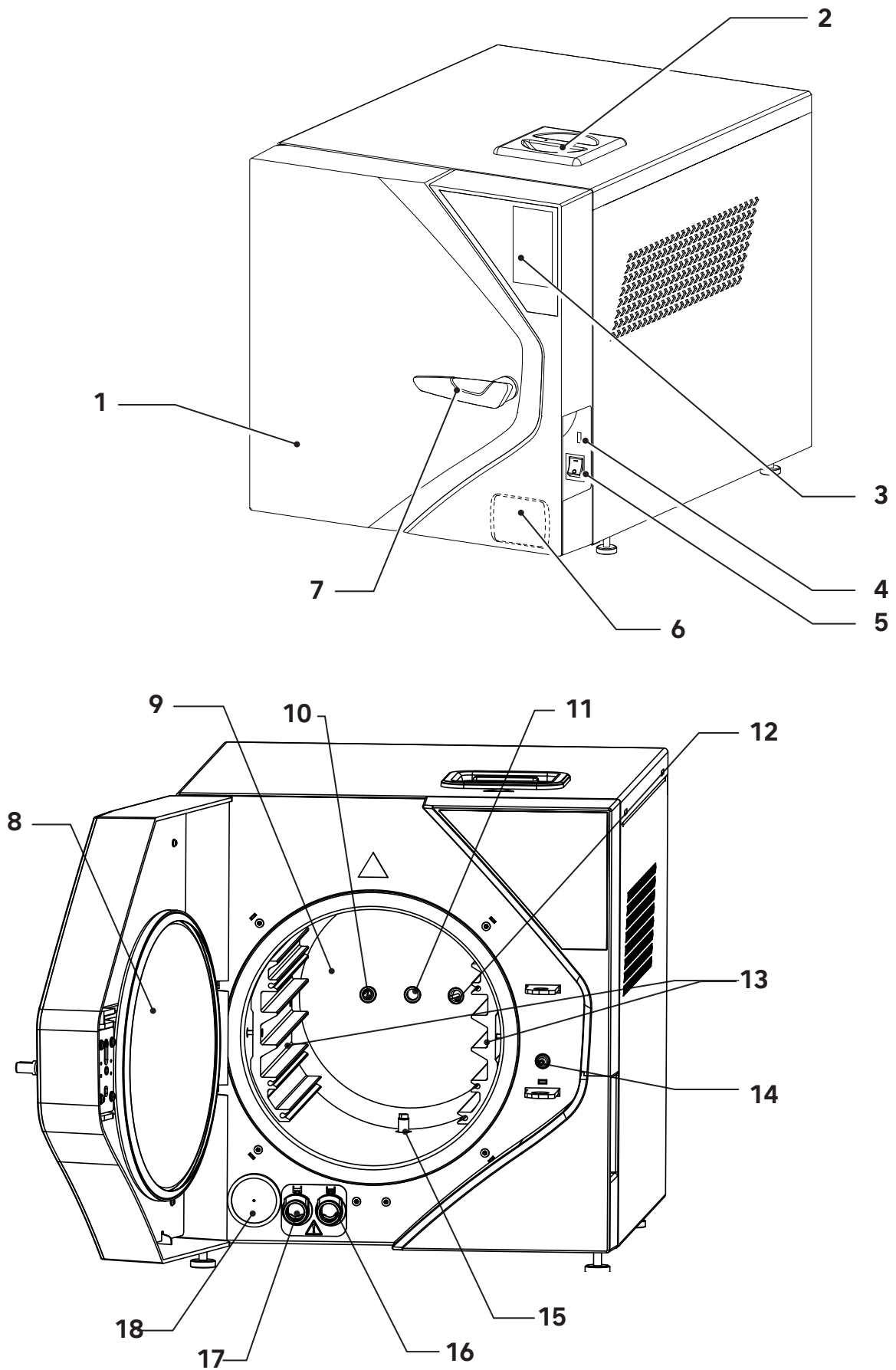

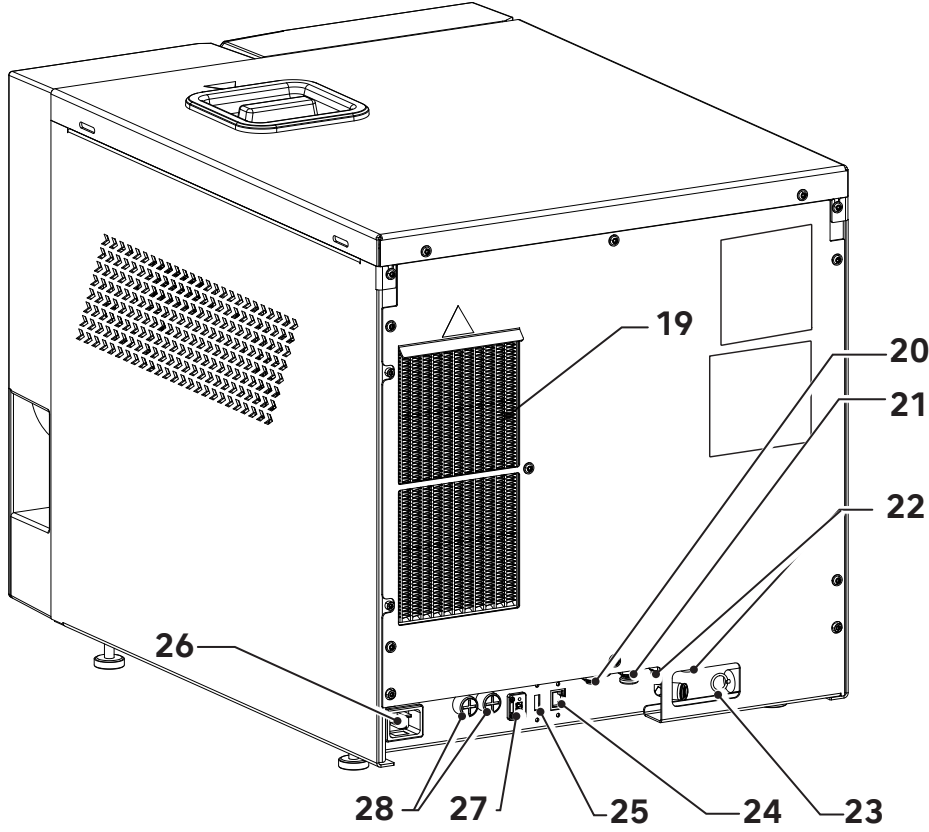

Position	Description
1	Door
2	Clean demineralized water tank input
3	Operator panel
4	Front USB port
5	Main switch
6	Printer (optional)
7	Handle
8	Steel sterilizing chamber closure disc
9	Sterilization chamber
10	Safety valve connection
11	Pressure sensor
12	Temperature sensor
13	Tray Holder
14	Locking Electromagnet
15	Drain Filter
16	Clean water tank drainage connection
17	Used water tank drainage connection
18	Bacteriological filter
19	Condenser
20	Clean water load external connection
21	Used water drain external connection
22	Overflow drain connections
23	Pressure safety valve
24	Ethernet port (LAN)
25	Rear USB port (not usable for firmware update).
26	Power outlet
27	AUX port
28	Electrical protection fuses

3.5 Components supplied with the sterilizer

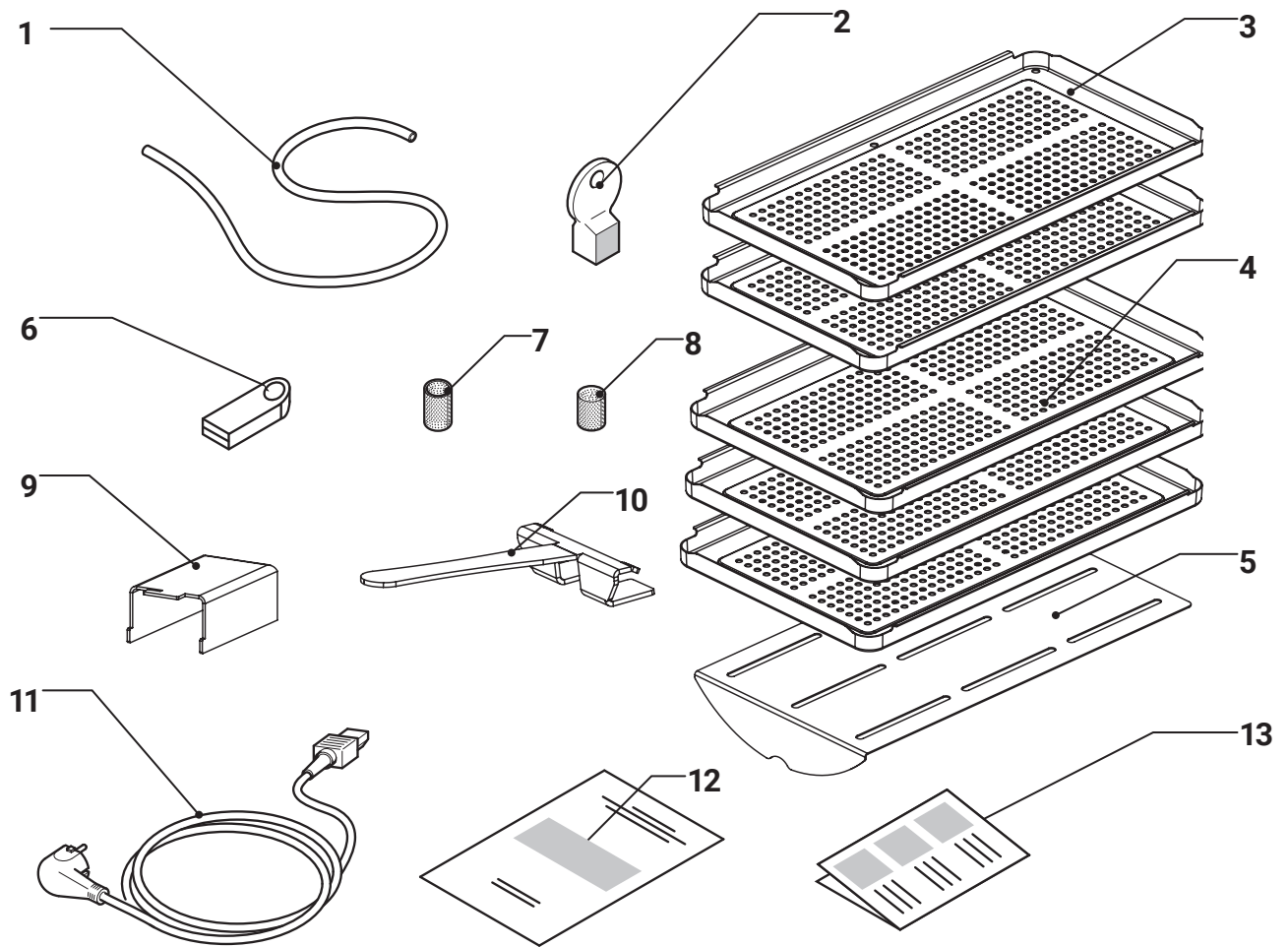

129A0005

Position	Description
1	Rubber hose
2	Water filter extraction key
3	Small tray (2 pieces)
4	Large tray (3 pieces)
5	Diffuser plate
6	USB-key with operator manuals and general catalog (it can also be used for cycle downloads)
7	Tank water filter
8	Chamber water filter
9	Rear spacer (2 pieces)
10	Rack insertion and extraction clamp
11	Power Chord
12	Warranty certificate
13	Quick guide

3.6 Size and weight of package

Packaging size: 570 x 672 x 780 (L x A x P)

Total weight of iClave 18 package: 62 kg

Total weight of iClave 24 package: 64 kg

i Keep the original packaging intact.

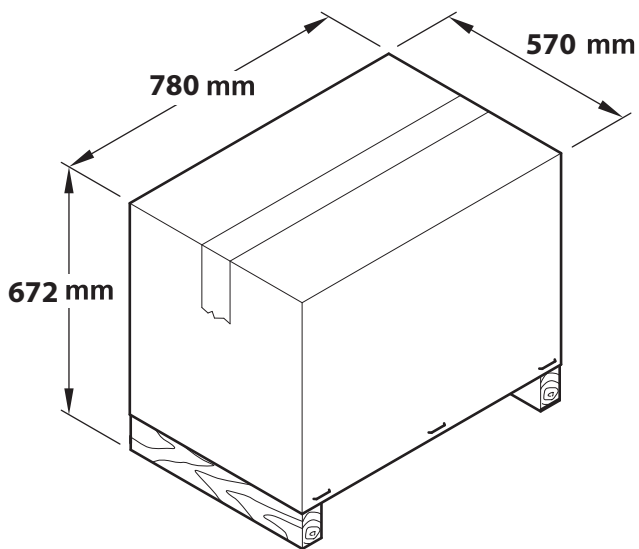

3.7 Size and weight of sterilizer

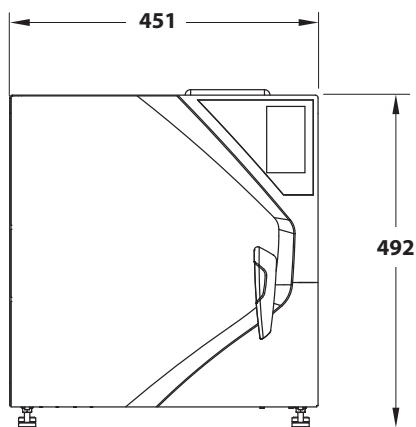

	iClave 18	iClave 24
STERILIZER		
Net unladen weight	52 kg	55 kg
Weight with full load	64 kg	67 kg
STERILIZATION CHAMBER		
Diameter	265 mm	265 mm
Depth	382 mm	475 mm
Volume	18 litres	24 litres

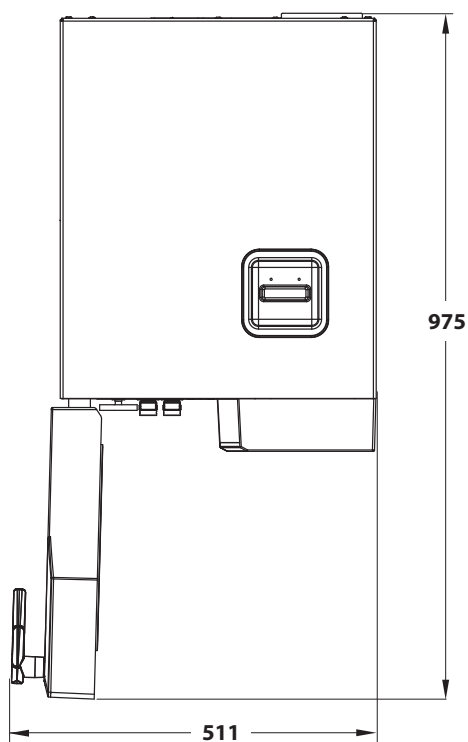
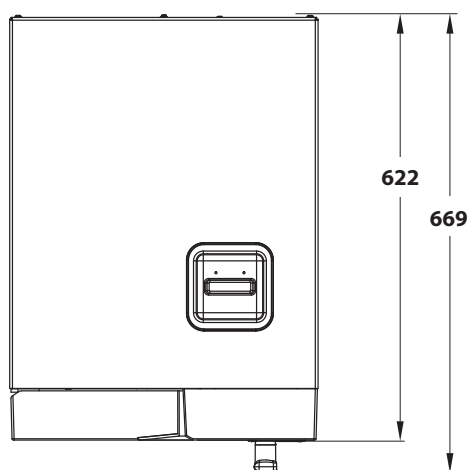

3.8 Technical specifications

		iClave 18	iClave 24
Chamber dimensions	Diameter	265mm	265mm
	Depth	382mm	475mm
Chamber volume		18 lt	24 lt
Maximum load (including trays)	Solid load	5,0 kg	7,0 kg
	Porous load	1,5 kg	2,0 kg
Heating time		6'30" from room temperature 1'30" from preheated chamber	
Sterilization time	B Universal	4'	4'
	B Prion	18'30"	18'30"
	B Fast	3'30"	3'30"
	B121	20'30"	20'30"
	S Fast	3'30"	3'30"
Drying time	B Universal	10'	10'
	B Prion	14'	14'
	B Fast	5'	5'
	B121	16'	16'
	S Fast	7'	7'
External dimensions		451 (W) x 492 (H) x 669 (L)	
Net weight		59 kg	61 kg
Power voltage		230 V~ ±10 %	
Frequency		50/60 Hz	
Maximum power consumption		2300 W (10 A)	
Average consumption		295 W (1,35 A)	
Standby consumption		50 W (0,2 A)	
Fuses		2 x T 16A H, 400V (6,3x32mm)	
Clock battery		Internal, not replaceable by the operator: CR2032	
Double water tank		5 l (clean water tank) 5 l (used water tank)	
"Average" water consumption for standard cycles 134°C - 121°C - 3 vacuum		600 cc ÷ 700 cc	800 cc ÷ 1050 cc
Vacuum pump		13 l/min - 0.96 bar	
Bacteriological filter		0.3 µm at 99.97 %	
IP rating (in accordance with EN 60529)		IP20 [1]	
Separate heating system		Band heater with separate power distribution.	
Heat transmitted to the environment at 23°C		2,16MJ	

Sound emission	60 dB(A)
Operating cycle	Continuous
Pollution level	2 (IEC 61010-1)
Transient overvoltage	II (IEC 61010-1)
Water conductivity control	LOW/HIGH WATER CONDUCTIVITY (in reference to a value of 15 microsiemens)
Available volume on trays	10 l
Maximum chamber temperature	137°C (-0+2°C)
Safety valve intervention pressure [2]	2,6 bar
<p>[1] Classification of the device with respect to the ingress of liquids (second digit of the IP20 degree, or 0), and protection from dangerous parts or against the access of solid foreign bodies (first digit of the IP20 degree, or 2).</p> <p>The first characteristic digit indicates that:</p> <p>2 - Degree that the casing provides for the protection of people against access to dangerous parts (finger of test), preventing or limiting the penetration of a body part or a contested tool into the casing by a person (test gauge with a diameter of 12 mm) and at the same time the degree that the casing provides for the protection of the equipment against the penetration of solid foreign bodies (test sphere of diameter 12.5 mm);</p> <p>The second characteristic figure indicates the degree of protection of the casing against harmful effects on the equipment due to the penetration of liquids into the casing.</p> <p>0 - no protection</p>	
<p>[2] Pressurized container conforming to Directive 2014/68/UE (PED)</p>	

3.9 Labels and symbols

3.9.1 Labels present on the back of the sterilizer

There are 2 labels which are fixed in the back of the sterilizer: the serial number label and the UDI label. These labels contain, in addition to the CE marking, important data for operation, already indicated in the technical data table, and the serial number.

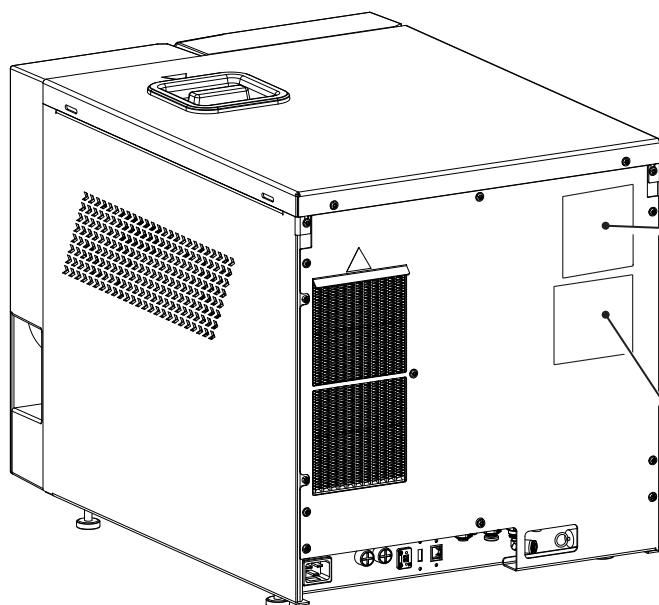

NSK MADE IN ITALY		NSK Dental Italy S.r.l. Via dell'Agricoltura, 21 36016 Thiene - VI - Italy +39 0445 820070	
Small Steam Sterilizer			
#	iClave XX	REF	92412B0100
MD	XXXX-XX-XX	SN	GXXXXXXXXX
230 V- 50/60Hz 2300W		10A	
T 16AH, 400V 6,3x32mm		S.V.P.I. 2,6 bar	
Max W.P. 2,35 bar		Max W.T. 135°C	
EN13445-3 Ed.2021 Issue 1			
Fluid Group 2 Category I			
Max. A.P. 2,6 bar		Chamb. CapacityXXI	
D.T. 140°C		D.P. 2,6 bar	
Test pressure 4,3 bar			
Ts min +5°C		Ts Max +140°C	

MD
CE
0051
CE

Attention, consult instructions for use

UDI

+D910PB0/\$\$+7PB023582L%

3.9.2 Labels and symbols present on the packaging

The sterilizer packaging contains printed symbols that represent the storage correct conditions, while during the autoclave packing a label is glued which contains all autoclave information..

MATERIALE CONFORME \ COMPLIANT GOODS

REF	92412B0100P		NSK MADE IN ITALY
#	iClave XX		
SN	GXXXXXXXXX		
	XXXX-XX-XX		

UDI

+D910GDP1/\$\$+7GDP2600159

Small Steam Sterilizer
MD
CE
0051









NSK Dental Italy S.r.l.
Via dell'Agricoltura, 21 - 36016 Thiene - VI - Italy
+39 0445 820070 - servicesterilization@nsk-italy.it





003

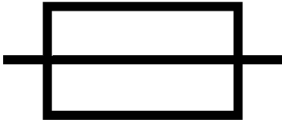



iClave 24
MADE IN ITALY

iClave
MADE IN ITALY

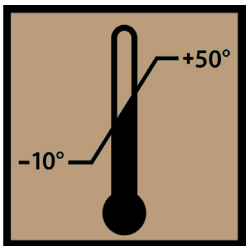
3.9.3 Symbols legend

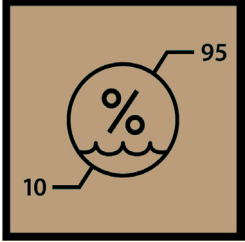
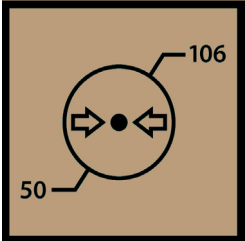
	Symbol	Description
1		Symbol for manufacturer.
2	MADE IN ITALY	This is a merchandise mark indicating that a product is designed, produced and packaged entirely in Italy.
3		Symbol for manufacturer. The data given next to this symbol identifies the manufacturer. NOTE: this symbol must be accompanied by the name and address of the manufacturer.
4	NSK Dental Italy S.r.l.	Manufacturer's name.
5	Via dell'Agricoltura 21, 36016 Thiene (VI) IT	Manufacturer's address.
6		Date of manufacture. The date given beside this symbol is the date of manufacture.
7		Serial number.
8		Device model.
9		Catalogue number
10	230 V~ 50/60 Hz 2300W	Type of power supply, frequency and Maximum power.
11	10A	Maximum absorbed current.
12		Type of fuses.
13	S.V.P.I. 2,6 bar	Safety valve intervention pressure.
14	Max W.P. 2,35 bar	Maximum work pressure.
15	Max W.T. 135°C	Maximum work temperature.
16		Medical device.
17		The CE marking certifies that the product meets the standards applicable in the EU member states (see declaration of conformity).

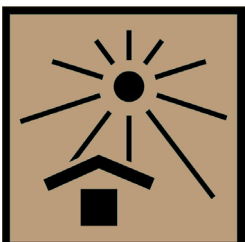
18	0051	Identification number of the notified body. Notified body: IMQ S.p.A. via Quintiliano 43, 20138 Milan (MI), Italy.
19	EN13445 Ed.2019 Issue 4	Design code for the sterilization chamber.
20	Fluid Group 2	Fluid classification according with the PED directive.
21	Risk Category I	Sterilization chamber risk category.
22	Max. A.P. 2,6 barg	Maximum allowable pressure.
23	24l / 18l	Sterilization chamber nominal volume.
24	D.T. 140°C	Sterilization chamber project temperature.
25	D.P. 2,6 barg	Sterilization chamber project pressure.
26	Test Pressure 4,3 barg	Idrostatic test pressure.
27	Ts min +5°C / Ts max +140°C	Chamber minimum and maximum temperature.
28		Caution, carefully read the instructions for use before using the device. Attention residual risks.
29		Symbol for separate waste collection of electrical and electronic devices, in conformity with Directive 2012/19/EU (WEEE).
30		Symbol is used to indicate the need for the user to consult the instructions for use.
31		Symbol is used to indicate a vector that contains information about the unique identifier of the device.
32		UDI Barcode: The barcode follows the format HIBCC and is printed with AIDC technology or in the form human readable (HRI).
33		Temperature limit: Indicates the temperature limits to which the medical device can be safely exposed.

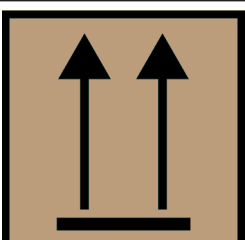
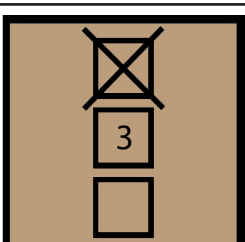
34		<p>Humidity limitation: Indicates the range of humidity to which the medical device can be safely exposed.</p>
35		<p>Atmospheric pressure limitation: Indicates the range of atmospheric pressure to which the medical device can be safely exposed.</p>
36		<p>Fragile, handle with care: Indicates a medical device that can be broken or damaged if not handled carefully.</p>
37		<p>Keep away from sunlight: Indicates a medical device that needs protection from light sources and from heat.</p>
38		<p>Keep dry: Indicates a medical device that needs to be protected from moisture.</p>
39		<p>This way up: To indicate correct upright position of the transport package.</p>
40		<p>Stacking limit by number: To indicate that the items shall not be vertically stacked beyond 4 pieces, either because of the nature of the transport packaging or because of the nature of the items themselves.</p>

4. Installation

4.1 Unpacking and transport

The packaging of the sterilizer consists of a wooden pallet on which the sterilizer is placed, with adequate protective padding by a corrugated cardboard casing secured to the pallet with straps. Place the package on a level surface free from clutter to facilitate easy opening and safe extraction of the sterilizer.



There may be a small amount of water inside the chamber due to a residue inside the autoclave hydraulic circuit.

- Remove the staples / strapping holding the casing to the pallet.
- Remove the cardboard casing.
- Remove the accessory kit, corner and edge protection from the sterilizer.
- Lift the sterilizer and position it in the place of installation.

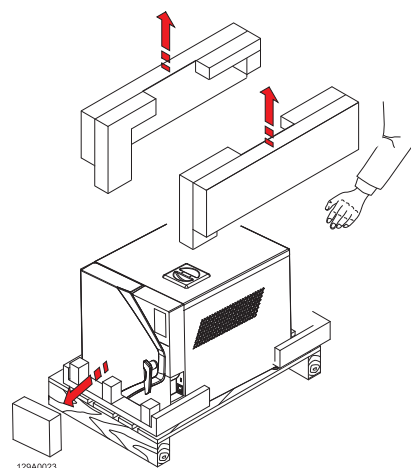
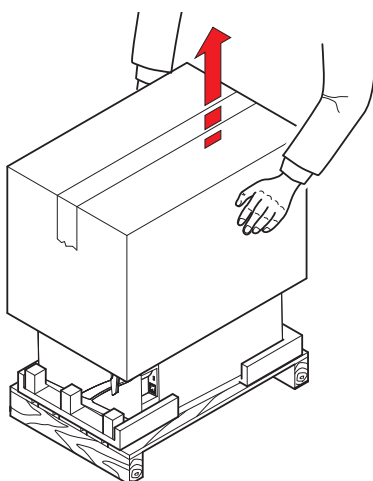
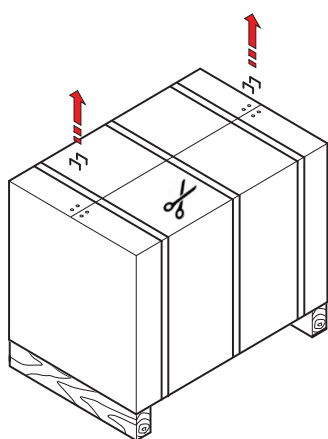

Lifting, transporting and positioning the sterilizer in the place of installation should be performed by two people.



It is recommended to keep the packaging in a cool and dry place.

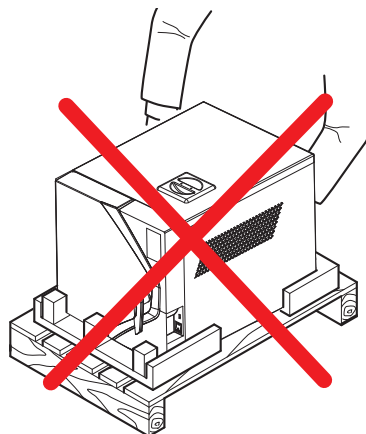
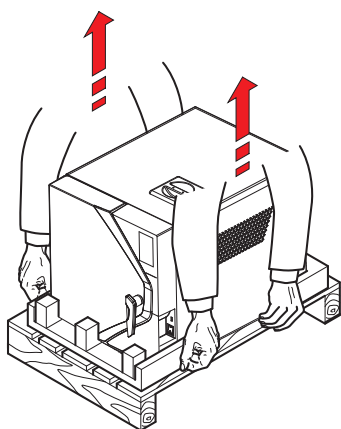

4.2 Positioning

Check that the power supply voltage to the device matches that one shown on the regulatory label on the rear panel (fig.1), that the power outlet is designed to supply at least 16A and that it has an earth connection.

If the installation makes the main power switch inaccessible, a specially dedicated accessible electrical disconnection switch should be provided.

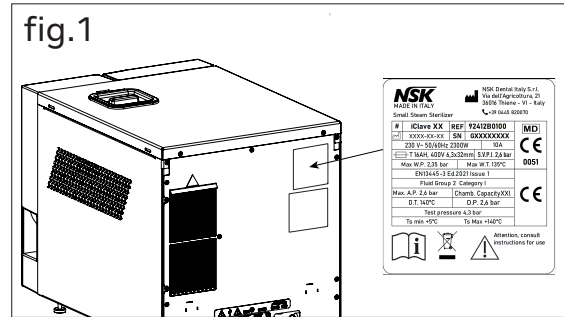

⚠ The manufacturer is not liable for damage to property or persons caused by electrical systems that are unsuitable or have no earth connections.

The device must be installed on a flat surface. If the support surface is perfectly horizontal, the front feet are already adjusted with a slight inclination to facilitate the flow of water during draining.

If the support surface is not perfectly level, adjust the front legs, raising or lowering them to obtain a slight inclination (fig.2).

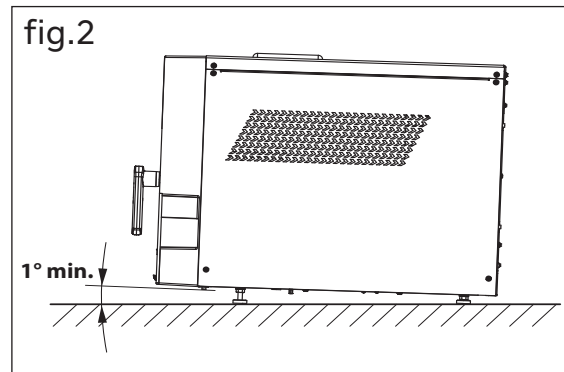

⚠ Do not place the device on a fragile surface that could be damaged or cause fire or smoke if hot objects fall.

For proper operation, leave a free space of at least 5 cm between the rear of the device and any wall, or use the supplied spacers (see chapter 4.3) (fig.3).

Do not install the device near heat sources or in damp or poorly ventilated spaces. The room must provide air circulation with at least 10 air changes per hour; a recirculating air ventilation system (e.g., an electric fan) cannot be used as an alternative.

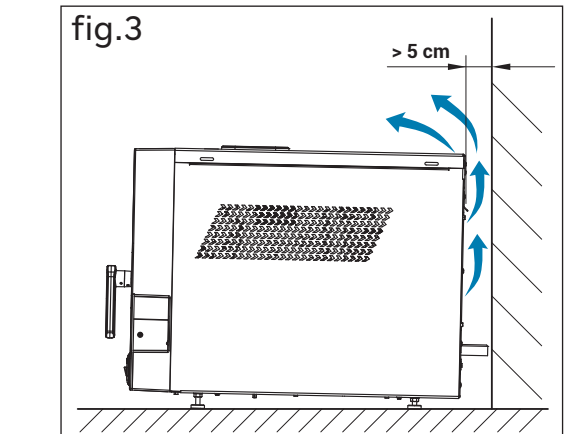

⚠ The safety valve is on the rear of the device. When triggered by excess pressure, it releases very hot steam into the environment. Position the device to avoid risk of burns to the operator.

In the case of built-in installation with a shelf above the device, a space of at least 5 cm should be left between the bottom of the shelf and the top of the device (fig.4).

Place the device on a mobile shelf with a sliding rail extraction system to allow filling of the deionized water tank, positioned on the top (fig.5).

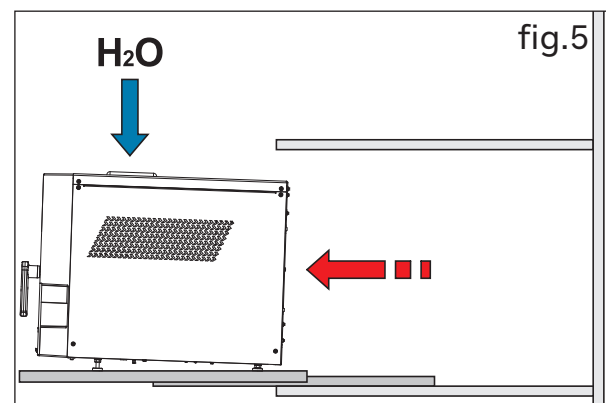
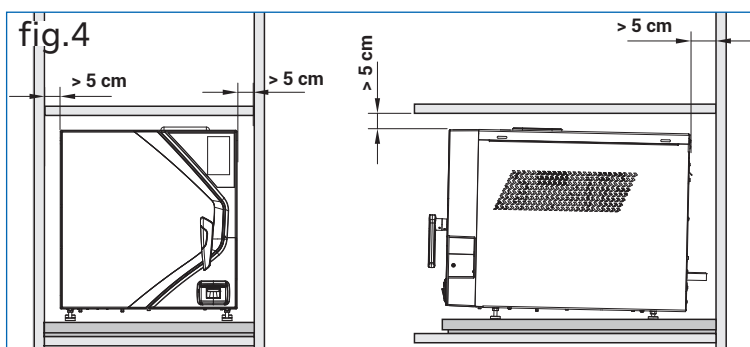

For installation inside a cabinet, leave a ventilation space of at least 5 cm between the bottom of the shelf and the top of the device (fig.6).

Place the device on a mobile shelf with a sliding rail extraction system to allow filling of the deionized water tank, positioned on the top, and access to the main switch at the back of the device. If the drain pipe under an adjacent sink is used for the drain, place the device at a greater height than the trap to allow proper drainage of the liquids by gravity.

STERILIZATION CHAMBER LOAD CAPACITY

The trays of varying widths to fit the circular shape of the sterilization chamber allow an increase of loading capacity.

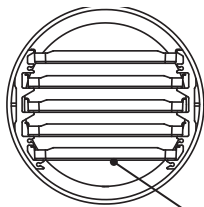

+ 20%

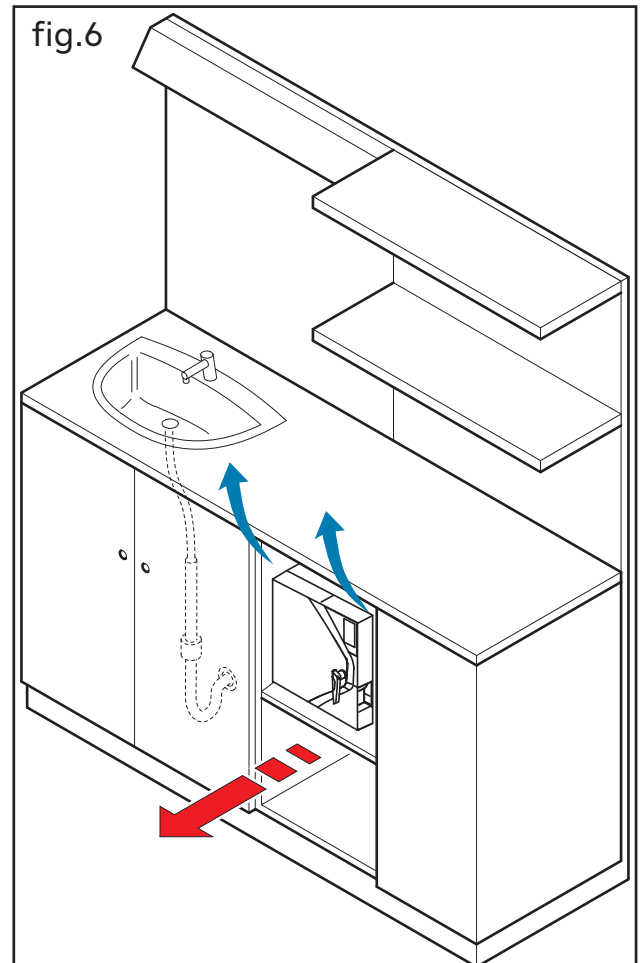

4.3 Installation of rear spacers (optional)

The supplied rear spacers ensure the minimum distance of the device from the rear wall, thus allowing its correct positioning for safe use.

To install the spacers follow the steps below:

- A. Insert the upper part of the two spacers into the horizontal slots of the device;
- B. Slide the spacers to the right to lock them and also insert them into the vertical slots.

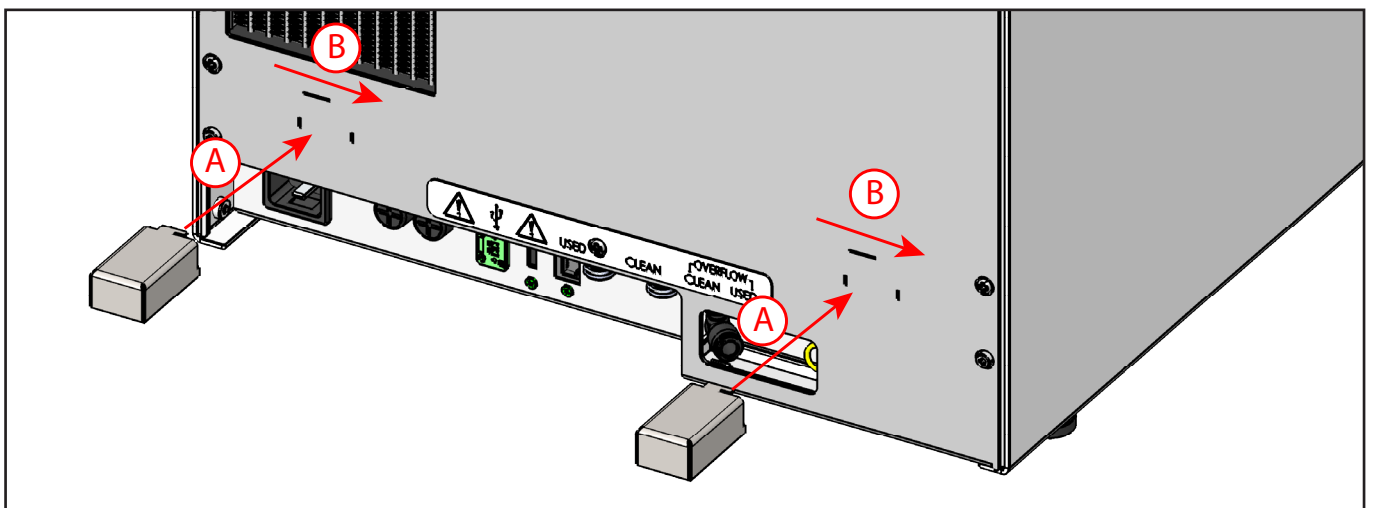

4.4 Initial start-up

 The following operations must be carried out by qualified and properly trained personnel. Incorrect procedures and settings can jeopardize the quality of sterilization and cause hazards.

- Check that the power supply has the right voltage and plug the power cord into the outlet.
- Switch on the device by the main switch.
- Set the desired language and press ENTER (Fig.2);
- Set the date format and press ENTER (Fig.3);
- Set the current date and press ENTER (Fig.4);
- Set the time format and press ENTER (Fig.5);
- Set the current time and press ENTER (Fig.6);
- Unlock the door by pressing the green button (Fig.7);
- Open the door (Fig.8);
- Remove the plastic protection inside the chamber (Fig.9);
- Confirm the message displayed on the screen by clicking YES (only after removing the plastic protection) (Fig.10);
- Select the desired performance mode (for details of each mode see par. 4.9.1.c) (Fig.11);

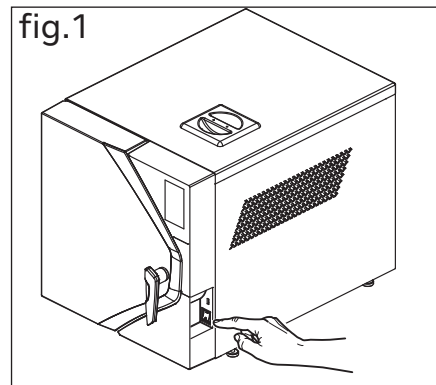

 When the "keep warm" mode is activated, a warning will display, advising against leaving heat-sensitive items inside. Click OK to confirm items inside the chamber are not present (see Fig.12).

- Close the door (Fig.13).
- Remove the tank cap and fill the demineralised water tank to the maximum level. When the tank is full, the device signals it with a message on the display and an acoustic signal (Fig.14).

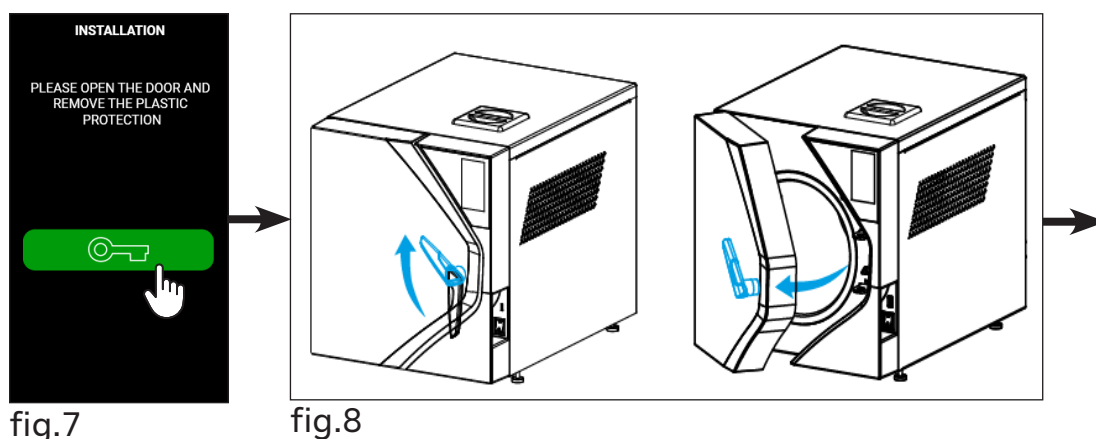
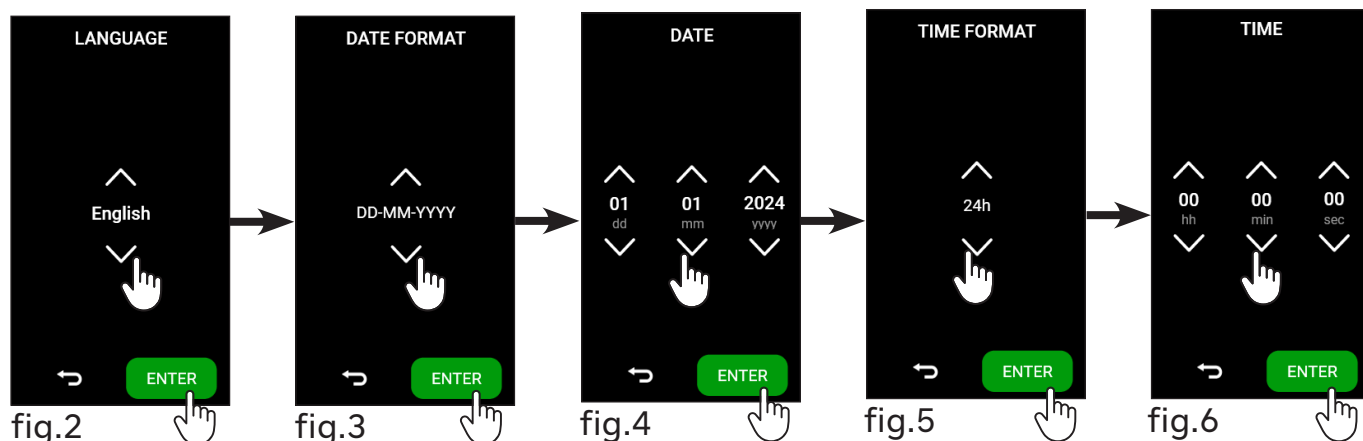

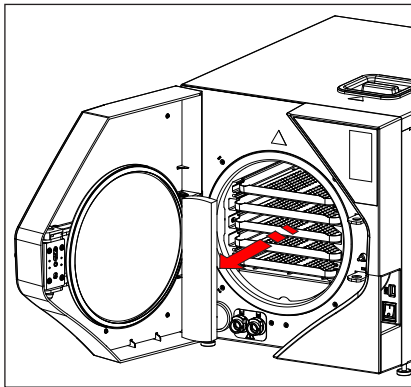

fig.9

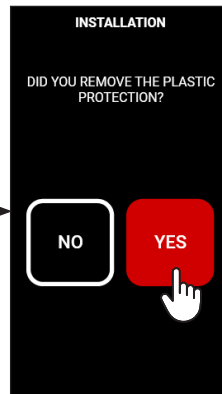

fig.10

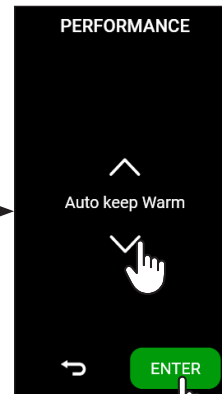

fig.11

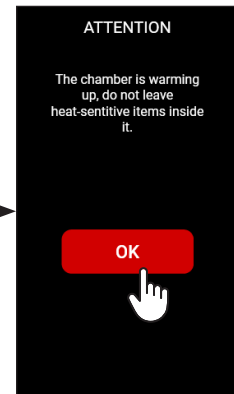

fig.12

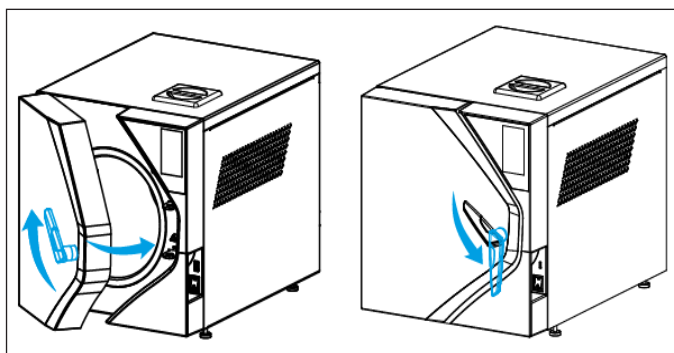

fig.13

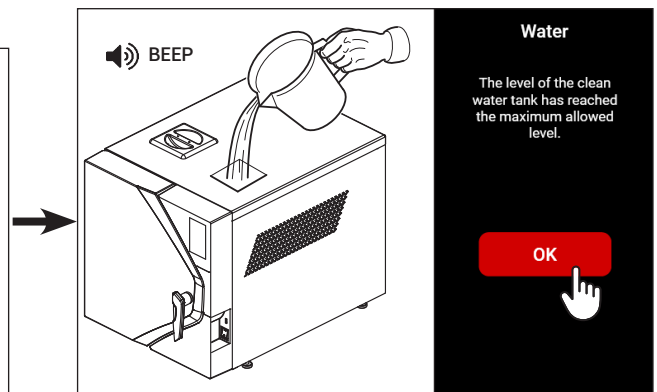





fig.14

 The use of poor quality demineralized water can leave limestone on the instruments, on the inside of the chamber and on the trays. It is recommended to use demineralised water with a conductivity $<15 \mu\text{S}/\text{cm}$ in accordance with the EN 13060 standard. Do not use domestic tap water, even if treated with a filter or water softener.

 Do not use battery water or other fluids or additives, as these can cause irreversible damage to the device and hazards to the operator.

■ For daily inactive periods, the main switch can be left in the ON position.

 The door remains locked when the device is switched off; if it is still locked when switched on, Press the unlock button in the main menu.

4.5 Home menu

The device has a **HOME** screen, where you can easily find the main menu of selectable programs and tests (**CYLCES** and **TESTS**), the selection of the most used cycles (**B UNIVERSAL** and **VACUUM**), the **INFO** menu (with a quick view of all general information of the device, such as serial number, firmware version and water conductivity) and the **SETTINGS** menu (to manage the parameters of configuration of the autoclaves, including date and time regulation, language selection, report download, connections with printers and ethernet).

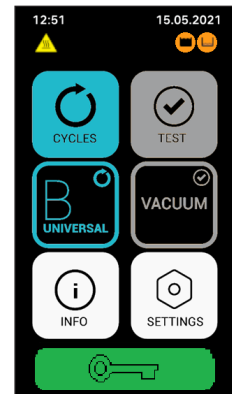

4.6 Cycles menu

The cycle selection procedure starts from the Main Menu by pressing the **CYLCES** button. For information on starting and managing a cycle, see chapter 5.

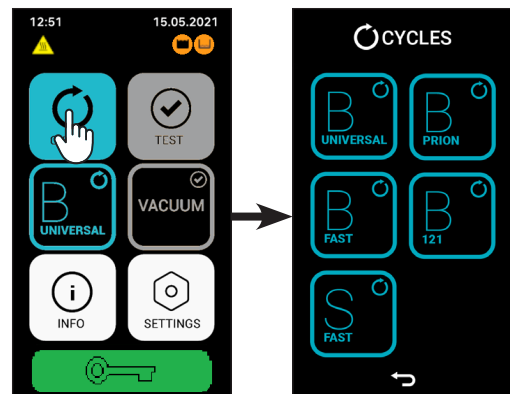

4.7 Test menu

The **TEST** menu allows to select the test cycles to check the performance of the device.

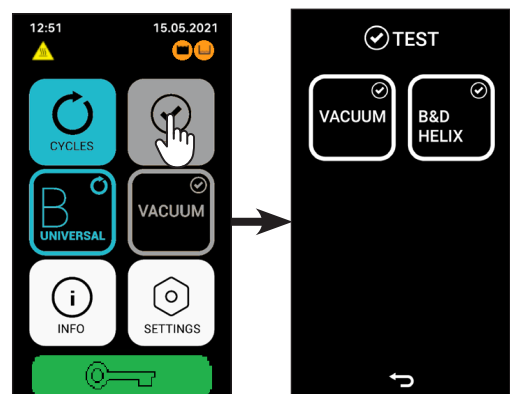

4.8 Info menu

The **INFO** menu allows to have a quick view of all general information of the device, in this menu all the information relating to the life of the device is available (software version, installation date, completed cycles), information regarding chamber pressure/temperature, clean water conductivity and device error messages.

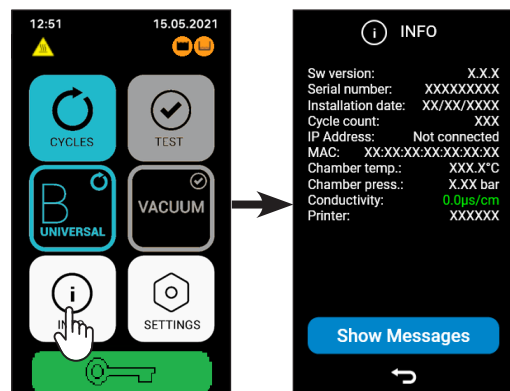

4.8.1 Device Messages

To view the error messages displayed on the device, just press the button "SHOW MESSAGE".

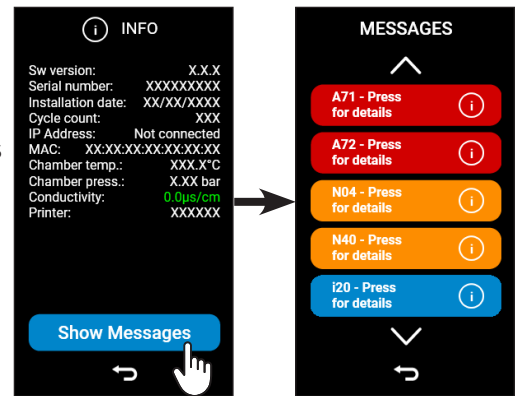

4.9 Settings menu

The **SETTINGS** menu allows to manage the settings of the different autoclave options, connections with printers and ethernet.

In this menu you can also manage the storage of reports on the device and all the advanced features relating to maintenance and technical assistance.

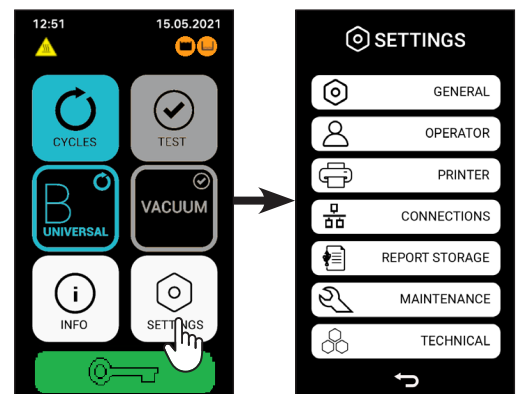

4.9.1 General settings

The **GENERAL** settings menu allows to manage the settings.

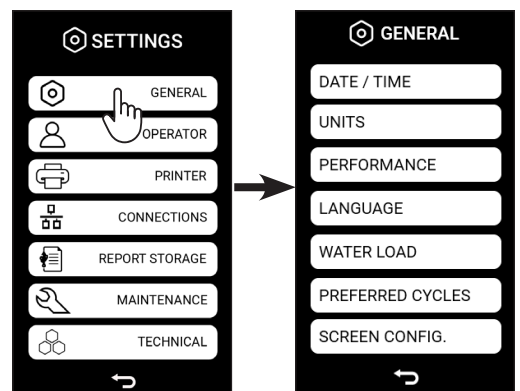

4.9.1.a Change date/time and their format

The date and time menu (**DATE / TIME**) allows you to change the date and time and their format.

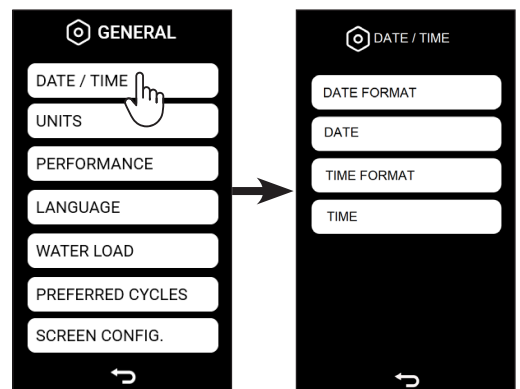

Date format modification: it is possible modify the date format by pressing the **DATE FORMAT** button.

The available formats are as follows:

- **DD-MM-YYYY;**
- **MM-DD-YYYY;**
- **YYYY-MM-DD.**

Once you press the button **ENTER**, the data is confirmed and the screen reverts to the previous menu.

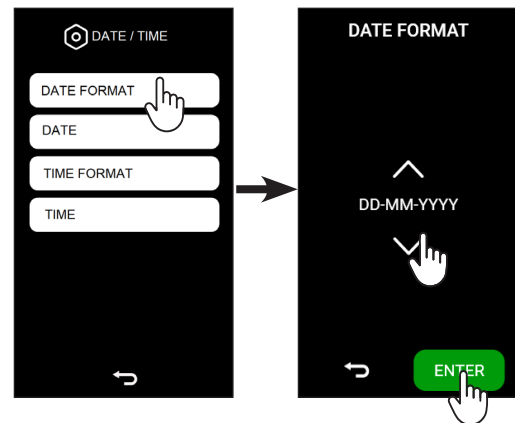

Date modification: it is possible modify the date by clicking the **DATE** button. Choose the correct date.

Once you press the button **ENTER**, the data is confirmed and the screen reverts to the previous menu.

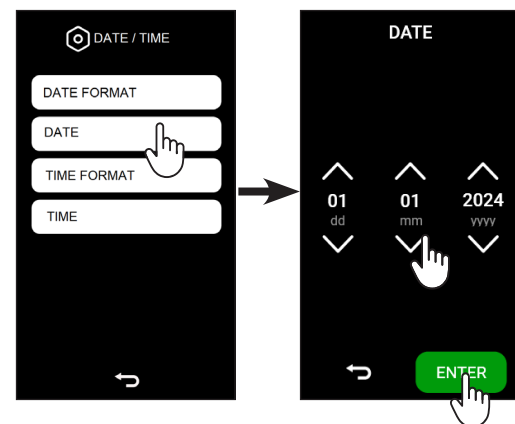

Time format modification: to change the time format, click the button **TIME FORMAT**.

The available formats are as follows:

- 24 H;
- 12 H.

Once you press the button **ENTER**, the data is confirmed and the screen reverts to the previous menu.

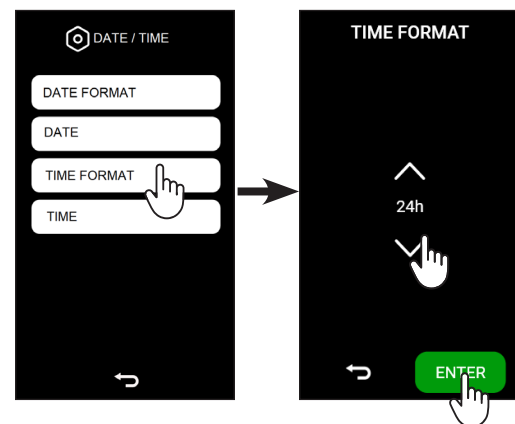

Time modification: to change the time, click the button **TIME**. Choose the correct time according to your time zone.

Once you press the button **ENTER**, the data is confirmed and the screen reverts to the previous menu.

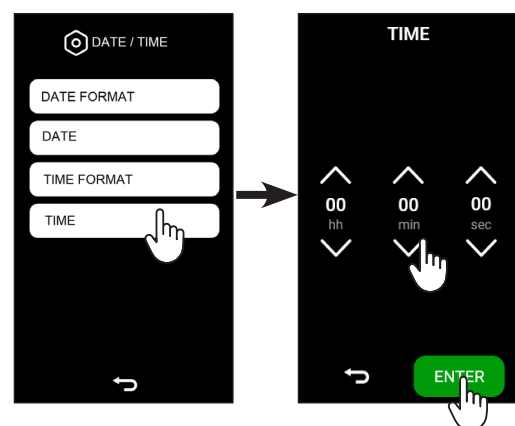

4.9.1.b Pressure and temperature unit modification

Pressing the **UNITS** button you access on the pressure measure unit menu. In this menu it is possible select the pressure and temperature measure unit to be displayed.

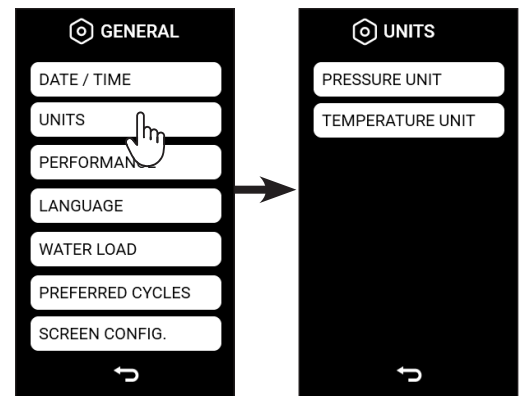

Pressure unit modification: it is possible modify the pressure unit by clicking the **PRESSURE UNIT** button. The available formats are as follows:

- **PSI;**
- **bar;**
- **Mpa.**

Once you press the button **ENTER**, the data is confirmed and the screen reverts to the previous menu.

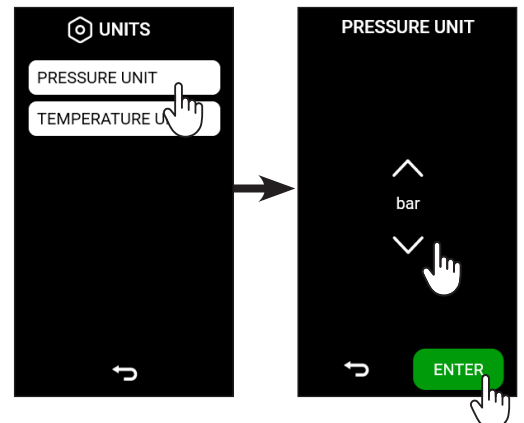

Temperature unit modification: it is possible modify the temperature unit by clicking the **TEMPERATURE UNIT** button. The available formats are as follows:

- **Celsius degrees (°C);**
- **Fahrenheit degrees (°F).**

Once you press the button **ENTER**, the data is confirmed and the screen reverts to the previous menu.

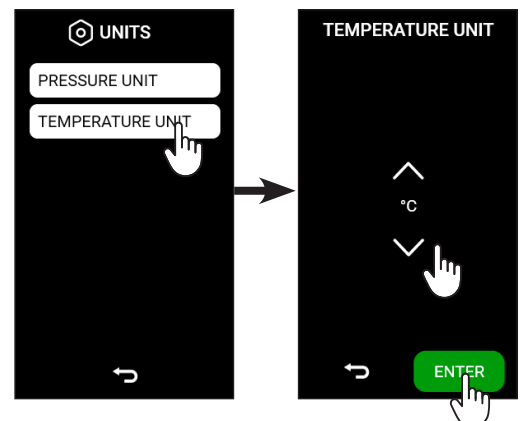

4.9.1.c Performance modification

By pressing the **PERFORMANCE** button you access a menu which it is possible to modify the setting according to the type of use.

The available settings are:

ECONOMY: dedicated setting for those who perform 1 or 2 cycles a day. The chamber is heated only when a cycle is started, at the end of the cycle the heating is deactivated, minimizing energy consumption. In this mode, as the chamber is not pre-heated, the cycle can last longer and can consume more water.

AUTO KEEP WARM: setting indicated for those who perform several cycles per day and/or want to optimize device performance. With this setting the chamber remains heated at an intermediate temperature in waiting to run new cycles. This avoids pre-heating times at each start of the cycle.

MANUAL KEEP WARM: setting indicated for each type of use.

With this setting, when the device is switched on and at the end of each cycle, a message appears on the display which invites the operator to indicate what he/she intends to do next. When switched on, it asks if you want to run the Vacuum Test (YES / NO), at the end of the cycle it asks if you want to keep the chamber heated (YES / NO). In this case, in based on the expected workload and your needs, you have the option to choose how to optimize the use of the device.

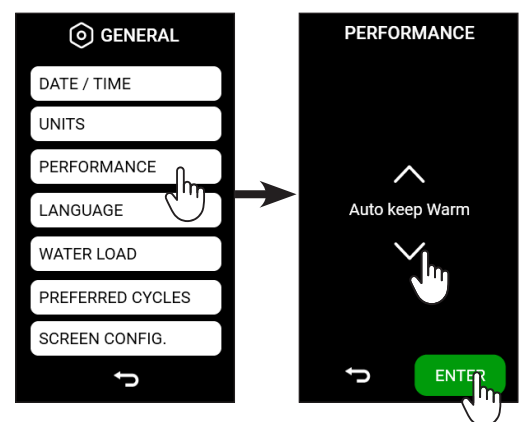

4.9.1.d Language modification

Pressing the **LANGUAGE** button you access on language menu. In this menu it is possible select the language to be visualized.

The available languages are the following: Italiano, English, Български, Čeština, Dansk, Deutsch, Ελληνικά, Français, Hrvatski, Magyar, Polski, Português, Română, Русский, Slovenský, Slovenščina, Svenska, Türkçe, Español, Eesti keel, Suomen kieli, Lietuvių, Latviešu, Nederlands.

Pressing the **ENTER** button the data is confirmed and the screen return to the general settings menu.

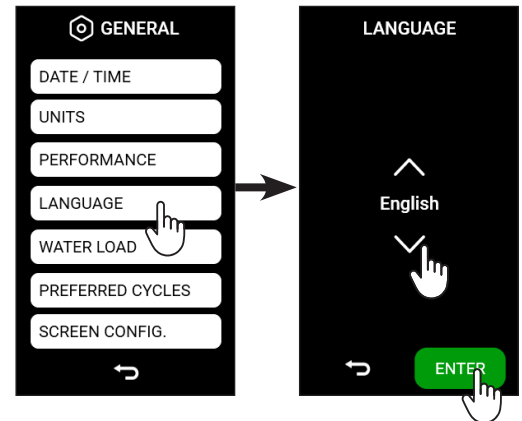

4.9.1.e Water Load Modification

Pressing the **WATER LOAD** button you access on the water load menu. In this menu it is possible to activate the automatic water loading mode in presence of an external demineralization system (optional).

Pressing the **ENTER** button the data is confirmed and the screen return to the general settings menu.

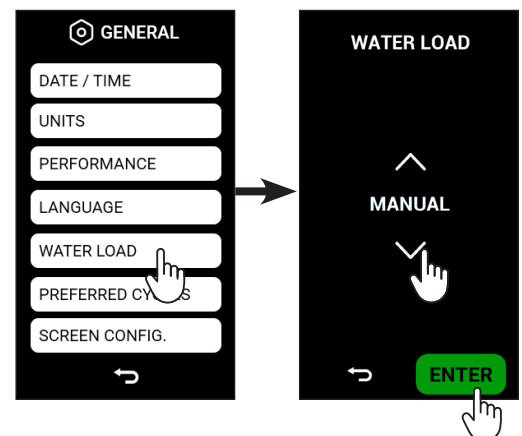

4.9.1.f Change the preferred cycles

By pressing the button **PREFERRED CYCLES** you access the editing menu of the two cycles to establish in the main screen (the central buttons in the display).

You can select from the following cycles: B UNIVERSAL, B PRION, B FAST, B 121, S FAST, VACUUM, B&D HELIX.

Pressing the **ENTER** button the data is confirmed and the screen return to the general settings menu.

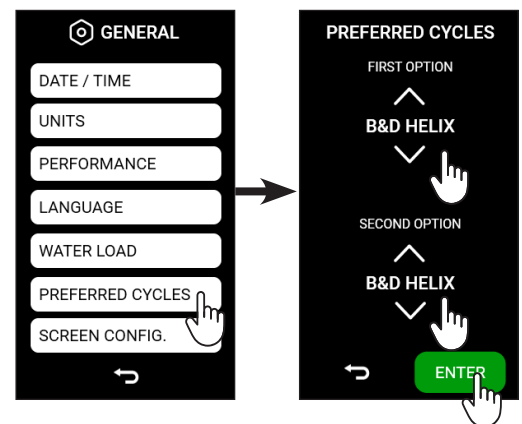

4.9.1.g change the screensaver clock type

By pressing the button **SCREEN CONF.** you access the menu to set up the type of clock to be displayed in stand-by mode. You can choose from analogue and digital clock.

Pressing the **ENTER** button the data is confirmed and the screen return to the general settings menu.

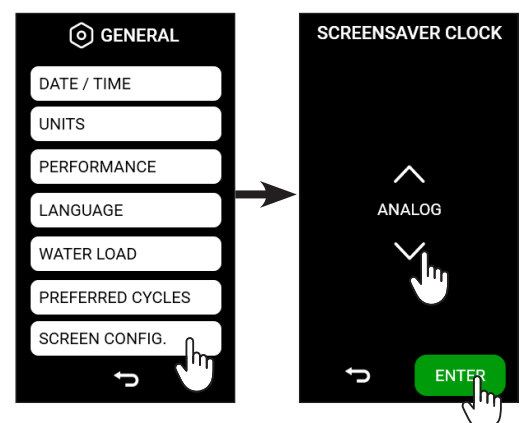

4.9.2 Operator menu

The **OPERATOR** menu allows to manage the operators and modify the operators name, password and the cycles they can use.

i When you access the menu the first time, a screen will appear showing a button to enable the mode "with operators".

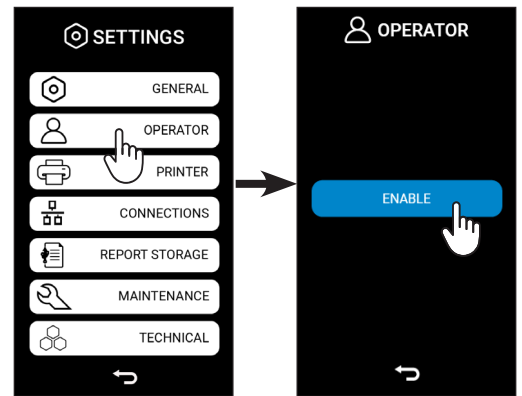

4.9.2.a Create a new operator

i During your first login, you will be required to establish an administrator operator.

Pressing the green button allows you to create a new operator. In this menu you will have to write the name of the operator, their password and the cycles they can perform. Pressing the + button the data is confirmed and the screen returns to the operator menu.

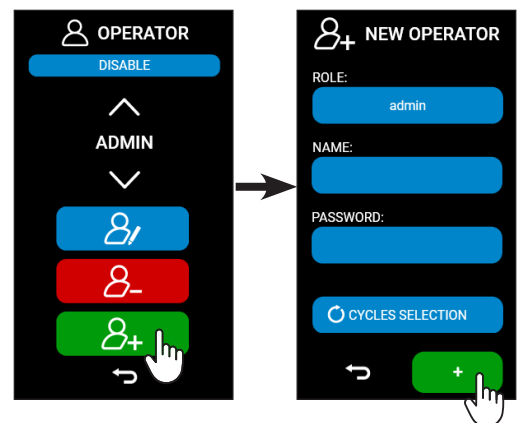

4.9.2.b Modification of an existing operator

Pressing the blue button allows you to change the profile of an operator. In the menu, you can update the operator's name, change their password, and configure the cycles they are permitted to run. Pressing the **ENTER** button the data is confirmed and the screen returns to the operator menu.

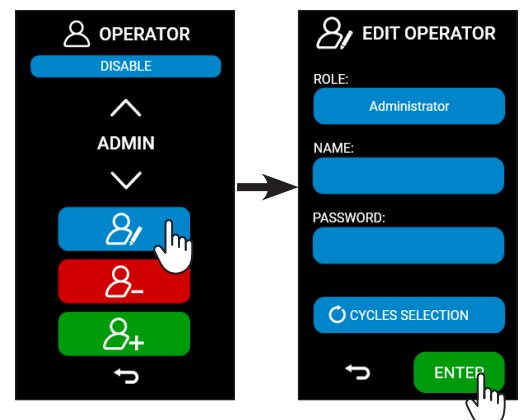

4.9.2.c Delete an existing operator

Pressing the red button you access on the delete operator menu. This menu allows you to delete an operator profile. By pressing the **YES** button, the chosen operator profile will be deleted, and the screen will revert to the previous menu.

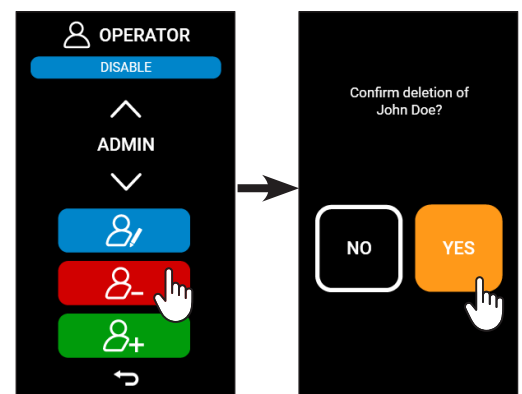

4.9.3 Printers menu

Pressing the **PRINTER** button you access on the printer management menu (if available). In this menu you can manage the internal label, the external printer that generate labels, the printer that generate reports and any reprints.

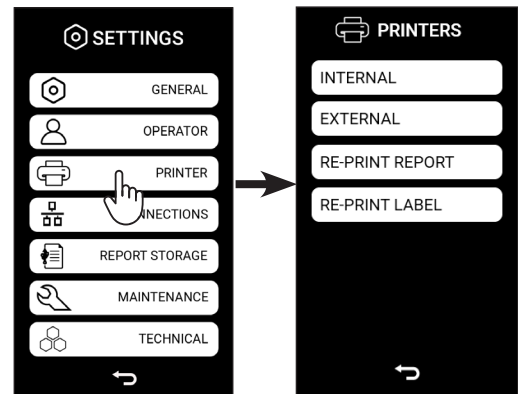

4.9.3.a Activation / Deactivation internal printer

i This menu appears exclusively when the device has an inbuilt printer.

Pressing the **INTERNAL** button you access on the menu for activating or deactivating the internal printer. Pressing the **ENTER** button the data is confirmed and the screen returns to the previous menu.

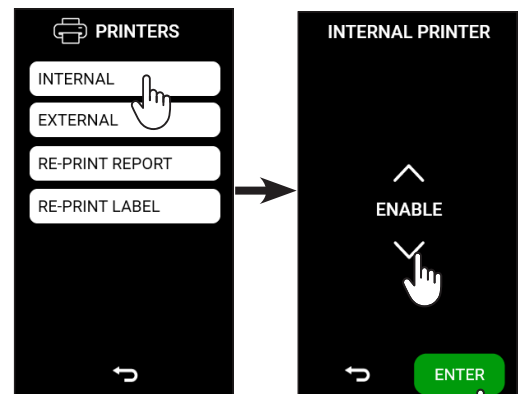

4.9.3.b Activation / Deactivation label printer

activate/ deactivate an external printer By pressing the button **EXTERNAL**, you can access the menu to activate or deactivate the external printer (if available). Here you can choose to disable the external printer or use it as a report or label printer (depending on the roll inserted).

i If you choose the LABEL mode by pressing ENTER , a new menu will appear to set the expiration days that must appear on each label).

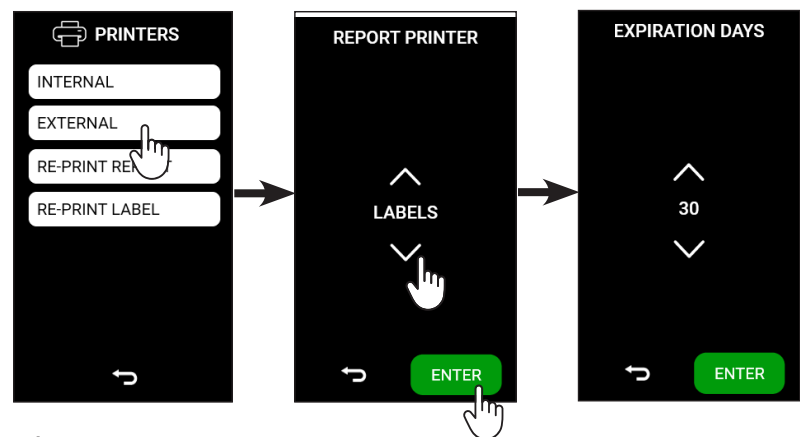

Pressing the **ENTER** button the data is confirmed and the screen returns to the previous menu.

4.9.3.c Reprint a report

By pressing the button **RE-PRINT REPORT**, you can access the menu to reprint a report. In the next menu choose the number of the report you want to print. Pressing the **ENTER** button the data is confirmed and the screen returns to the previous menu.

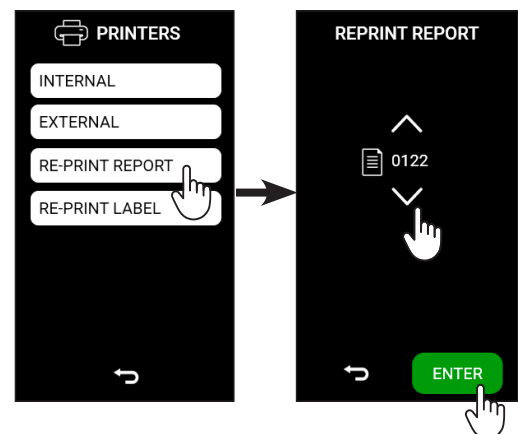

4.9.3.d Re-print the label

Pressing the **RE-PRINT LABEL** button you access on the menu for reprinting label. In this menu it is possible to select the cycle whose labels you want to reprint and the number of labels.

Pressing the **ENTER** button the data is printed and the screen returns to the printers menu.

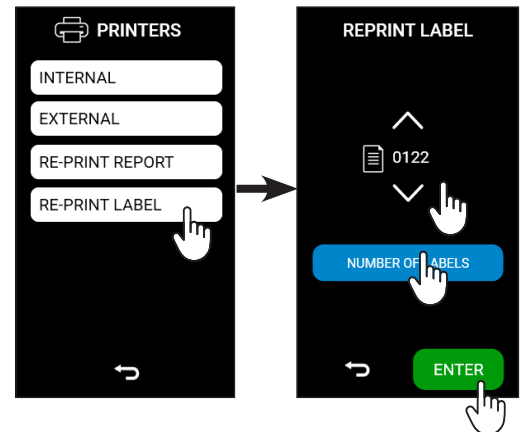

4.9.4 Connections menu

Pressing the **CONNECTIONS** button you access on the connections menu. In this menu it is possible to manage the LAN connections.

Once the device is wired, through the appropriate Ethernet socket on the back, select the connection options on dynamic IP (**DYNAMIC IP**) or static (**STATIC IP**). (In **DYNAMIC IP** mode the IP address is assigned automatically).

Pressing the **ENTER** button the data is confirmed and the screen returns to the previous menu.

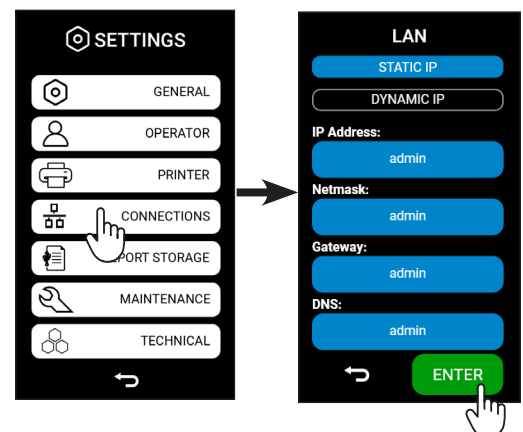

4.9.5 Archivation report menu

Pressing the **REPORT STORAGE** button you access on the archivation report. In this menu you can manage the report storage, export the reports to USB stick and format the USB stick.



The menu **USB STICK FORMAT**, **EXPORT REPORTS** and **EXPORT LOGS** appear only when a USB stick is inserted.

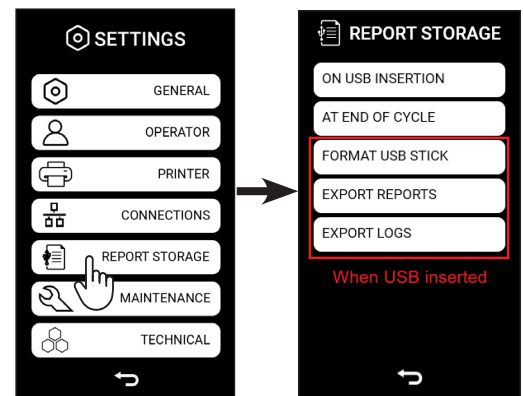

4.9.5.a Export report on usb insertion

By pressing the button **ON USB INSERTION** you can choose what to export when a USB stick is inserted. The available options are as follows:

- Do not export anything;
- Export only reports that have not yet been exported;
- Export everything.

Pressing the **ENTER** button the data is confirmed and the screen returns to the previous menu.

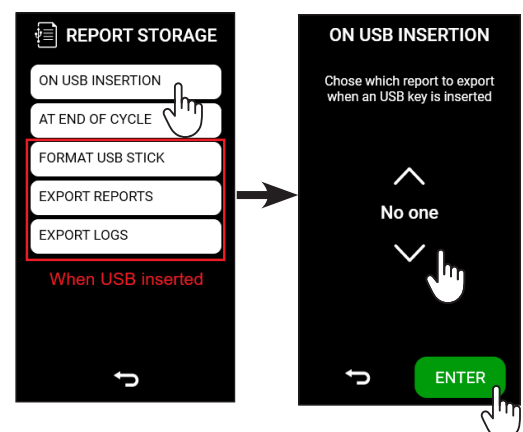

4.9.5.b Export report at the end of cycle

Pressing the **AT END OF CYCLE** button you can choose whether to automatically export the reports after the end of the cycle.

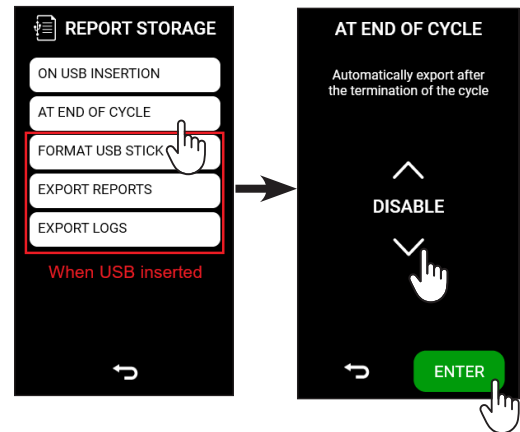

4.9.5.c Format USB Stick

Pressing the **FORMAT USB STICK** button you perform the formatting of the usb stick. Before the procedure is completed, a new menù will appear to confirm the decision. Formatting is recommended when using USB Sticks other than the original NSK ones.

i WARNING: Formatting will erase all contents on the USB drive.

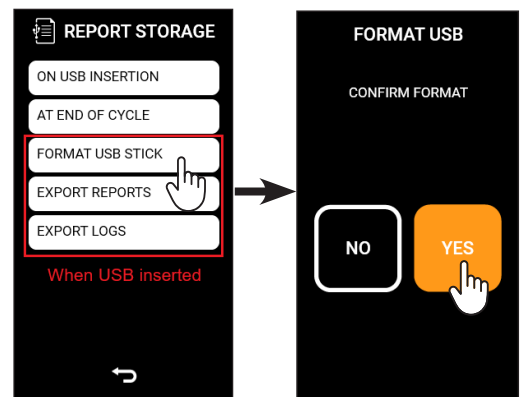

4.9.5.d Export report

By pressing the button **EXPORT REPORT**, you can choose which reports to export to the USB stick. You can export all cycles, cycles not yet exported or a desired range of cycles.

i It can take several minutes to download many files.

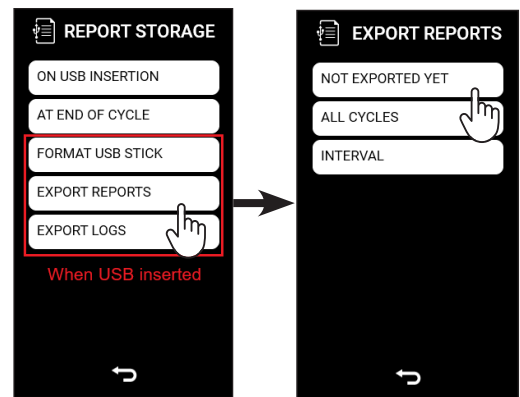

4.9.5.e Export Logs

By pressing the **EXPORT LOGS** button, cycle or system logs can be exported to the USB stick.

i It can take several minutes to download many files.

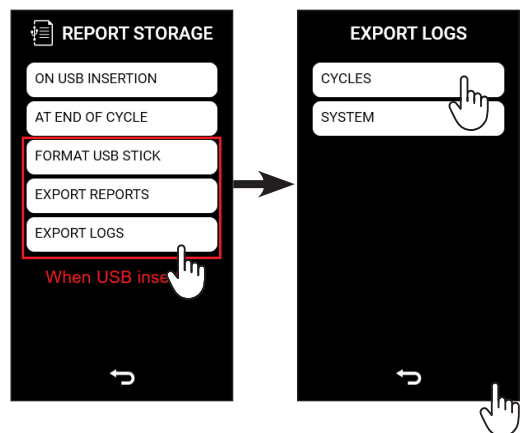

4.9.6 Maintenance menu

Pressing the **MAINTENANCE** menu you access the reset menu of the individual counters, specifically it refers to the spare parts of the bacteriological filter (**BACTERIOLOGICAL FILTER**), the door gasket (**DOOR GASKET**) and the cycle counter for inspection by a technical service.

To reset the counter, just press the blue button next to the chosen counter and a second screen will appear to confirm the reset. Pressing the **YES** button the counter will be reset and the screen will return to the maintenance menu.

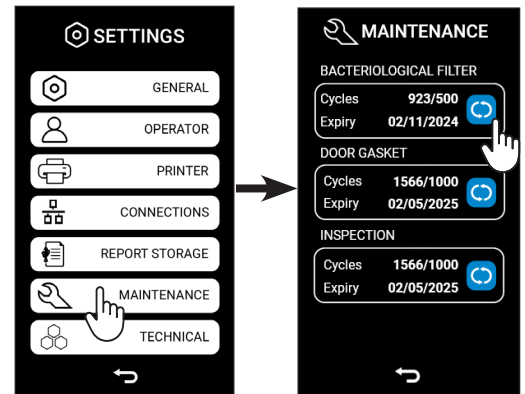

the reset of the DOOR GASKET and INSPECTION counter is password protected as it is authorized only by maintainers and technicians.

4.9.7 Technical menu

Pressing the **TECHNICAL** menu you access on the technical menu, reserved exclusively for the maintenance technician.

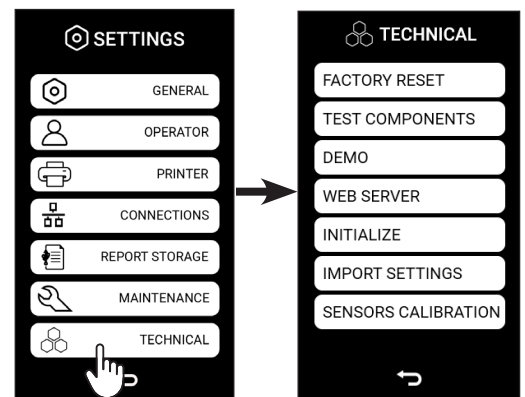

5. Using the sterilizer

5.1 Turning the sterilizer on

Turn the sterilizer on using the main switch on the right of the device.

At the end of the first commissioning (see par. 4.4) the **HOME** screen will appear. Buttons are arranged on the main menu as follows:

1. Cycles menu;
2. Preferred cycle/test 1 (the program set by default is B Universal; to change the program see par. 4.9.1.f);
3. Device information;
4. Test menu;
5. Preferred cycle/test 2 (the program set by default is Vacuum; to change the program see par. 4.9.1.f);
6. Settings menu;
7. Door Unlock;
8. Hot surfaces;
9. Used water tank full;
10. Fill the clean water tank.

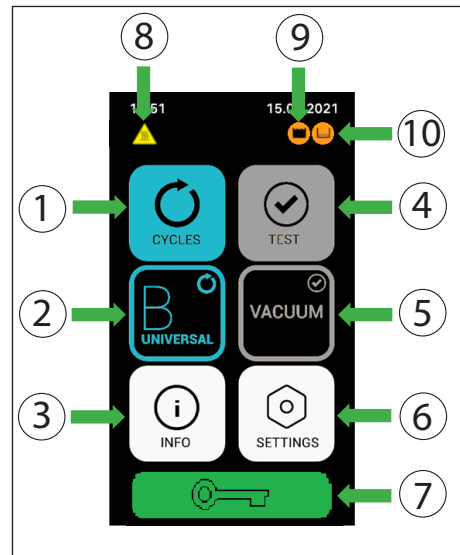

At this point, the sterilizer is ready to start one of the sterilization cycles (described in the following paragraphs). Arrange the material to be sterilized on the trays, place them in the chamber and close the door. How to check the correct water level in the tanks.

5.2 Opening / closing the door

To open the door you must first unlock it by pressing the button  on the touchscreen and then lift the handle counterclockwise up to the bottom. The handle travel is approximately 130°. The sequence of operations is described in the following images:

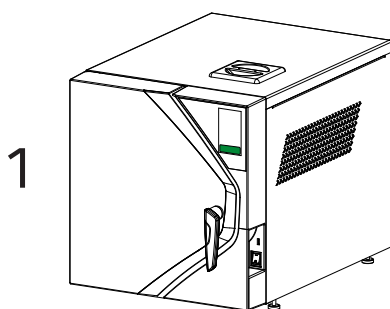

If the key icon is GREEN, it means that the door is closed. Pressing this icon will unlock the door and the icon will turn ORANGE



Never attempt to open the door if the icon has not turned ORANGE. With the door closed, keep the handle in an upright position.

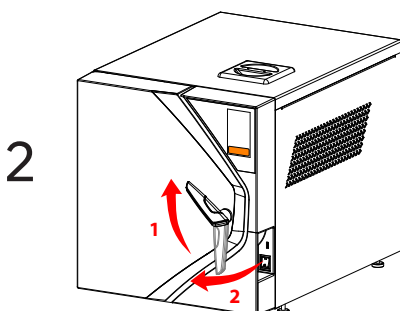

To open the door, rotate the handle upwards completely and then pull the door towards you.



The icon will remain ORANGE for 60 seconds before it turns back to GREEN, at which point the door cannot be opened.

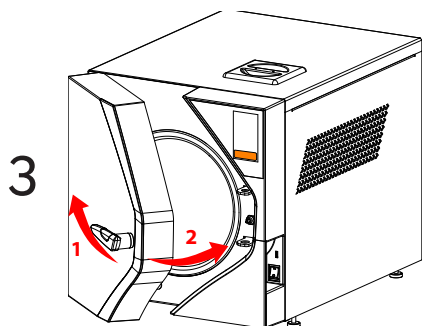

Before closing the door, fully lift the handle, then bring the door closer and turn the handle counterclockwise until it reaches the vertical position.

Note1: The door can always be closed, regardless of the colour of the icon, green or orange.

Note2: When a cycle is not being performed, the door can be kept ajar (not closed and locked) by simply leaving the handle in the horizontal position.

5.3 Tray arrangement and dimensions

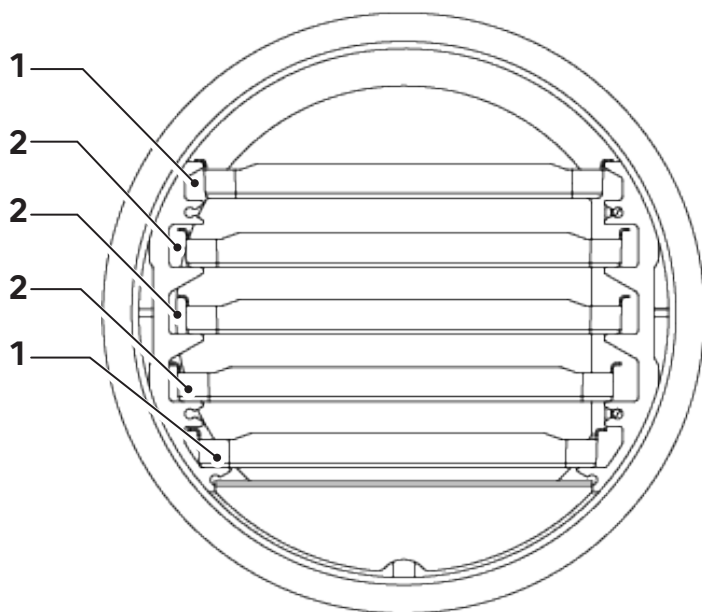

	iClave 18	iClave 24
1	196x292 mm	196x372 mm
2	214x292 mm	214x372 mm

5.4 Daily tests to check the sterilizer's performance

During the testing conducted by the manufacturer, in accordance with the regulations, the sterilizer undergoes thorough calibration tests and verification. These tests guarantee the performance of the device, except in the case of unauthorized repairs, tampering or improper use.

Although the device has an advanced diagnosis and process evaluation system, the operator has the responsibility of ensuring the maintenance of performance standards on a daily basis.

The frequency of these checks is determined locally by the healthcare protocols of the place of installation.

The manufacturer recommends running the following tests daily, in the morning, before using the sterilizer: **Vacuum**, **B&D Helix**, described in detail in the following paragraphs.

5.4.1 Vacuum test



Adhere to national and local guidelines regarding testing frequency.

The purpose of the **Vacuum test** is to ensure that the sterilization chamber is perfectly sealed. The manufacturer recommends running the test at the start of the day, before beginning the daily sterilization cycles.

The Vacuum test is activated with the machine unloaded, in standby mode and at an internal temperature below 40°C, which are the typical conditions of the state of the device at the start of a working day.

- Press the **TEST** button;
- In the Test menu, press the **VACUUM** button;
- If you want to program the Vacuum cycle, click the blue button highlighted on the screen, otherwise if you want to start the test immediately, press the **START** button.

The device starts automatically the Vacuum test, which lasts approximately 15 minutes. In case of negative test result, the display turns red, and the alarm code indicating an inadequate chamber condition is displayed (see to the 'Alarms' chapter).

5.4.2 B&D Helix test

The purpose of the **B&D Helix test** is to verify the perfect penetration of the sterilizing steam into the devices contained in the sterilization chamber.

The **B&D Helix test** can be activated when the sterilizer is on.

The manufacturer recommends conducting the test at the start of the day before commencing daily sterilization cycles; however, it can be carried out at any time while the sterilizer is operational.

If a **B&D Helix test** has been started by mistake, it can be interrupted by pressing the button **STOP**.

The device deletes the test initiated by mistake, and starts automatically a procedure to discharge the circulating liquids, and it switches to the stand-by mode, in which it is ready to be used in ordinary work cycle.

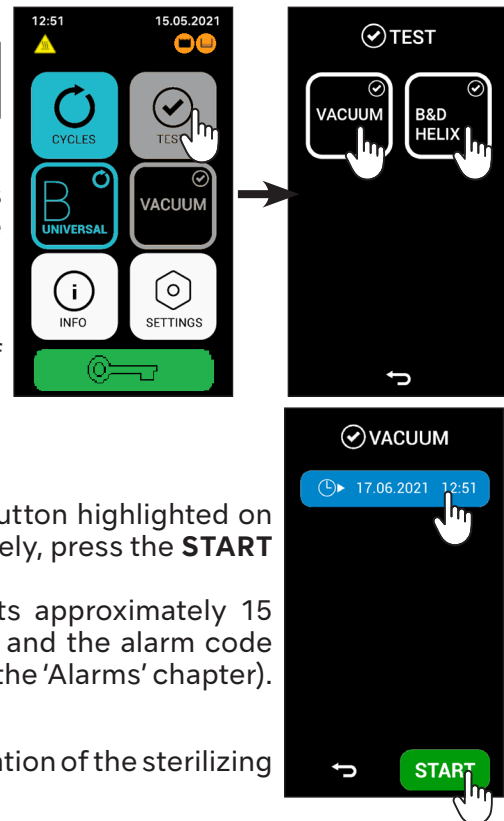

5.5 Preparing the material before sterilization

5.5.1 Preliminary operations

All the material to be prepared for sterilization is normally contaminated.

Before handling or moving contaminated materials or instruments, the following precautions should be taken:

- Wear rubber or latex gloves of suitable thickness and a face mask;
- Wash your hands, with the gloves already on, using a germicidal detergent;
- separate the instruments suitable for sterilization from those that are not;
- do not carry contaminated instruments in your hands, but always use a tray suitable for carrying instruments;
- be very careful of instruments with sharp parts that can puncture normal rubber gloves; in such cases, protect your hands with gloves of sufficient strength;
- once the handling and transfer of the contaminated materials is finished, carefully wash your hands while still wearing the gloves.

5.6 Treatment of materials and instruments before sterilization

 Failure to clean and remove organic residues from the instruments to be sterilized can affect the sterilization process and cause damage to the instruments and/or the sterilizer.

Clean and process the materials and instruments to be sterilized as indicated in the following points:

1. Rinse the instruments thoroughly under running water immediately after using them.
2. Divide metal instruments into groups, according to the type of material of they are made (e.g.: brass, aluminium, stainless steel, carbon steel, chrome-plated metal) in order to avoid electrolytic oxidation.
3. Perform a preliminary wash with an ultrasonic device that uses a mixture of water and germicidal solution (follow the manufacturer's instructions) or use a washer-disinfector. For best results, use a special detergent for ultrasonic cleaning, with a neutral pH.

 Solutions that contain phenols or quaternary ammonium compounds can cause corrosion to the instruments and the metal parts of the ultrasonic device.

4. After ultrasonic cleaning, rinse the instruments and visually check that all residues have been completely removed; if necessary, repeat the ultrasound cleaning or wash the instruments thoroughly by hand.

 To avoid mineral deposits on the instruments to be treated, use demineralized or distilled water for rinsing. If normal hard tap water is used, the instruments should be thoroughly dried.

5. When cleaning handpieces, in addition to the steps described above, run a wash cycle using a device specially designed for cleaning handpieces, which performs thorough internal cleansing together with lubrication.
6. For sterilization of porous materials, wash and dry the materials thoroughly before sterilization.

 For washing fabrics and porous materials in general, do not use detergent with high concentrations of chlorine and/or phosphates, such as bleach, as it can damage the support and the metal trays inside the chamber during the subsequent sterilization cycle.

5.7 Arranging the material on the trays before sterilization

Follow the guidelines below to obtain optimum effectiveness from the sterilization process and to preserve the life of the materials and instruments.

 It is required to use chemical and/or microbiological indicators for the qualification of the sterilization process (it is recommended to use class 5 or class 6 indicators according to the ISO 11140-1 standard).
Place a chemical sterilization indicator on each tray to avoid sterilising the same load twice or using unsterilized material. When sterilising wrapped material, place the chemical indicator inside one of the wraps.

- Arrange instruments of different metals, previously separated, on different trays;
- When sterilising instruments made of metal other than stainless steel, place a sheet of sterilization paper between the tray and the instrument to avoid direct contact between the two materials;
- position cutting instruments so that they do not come into contact during the sterilization cycle; if necessary, isolate them with gauze or cotton cloth;
- arrange receptacles and containers (tubes, cups, glasses, etc.) on their sides or in an inverted position as water accumulation must be avoided;
- do not place more instruments on the trays than they can contain; any overloading must be avoided;
- arrange the instruments with sufficient spacing and ensure that they remain separated throughout the sterilization cycle.
- position articulated pieces, such as scissors, in an open position;
- do not stack the trays one above another or in direct contact with the walls of the chamber; always use the tray support provided with the sterilizer;
- always use the supplied extraction clamp to insert or remove the trays from the sterilization chamber.

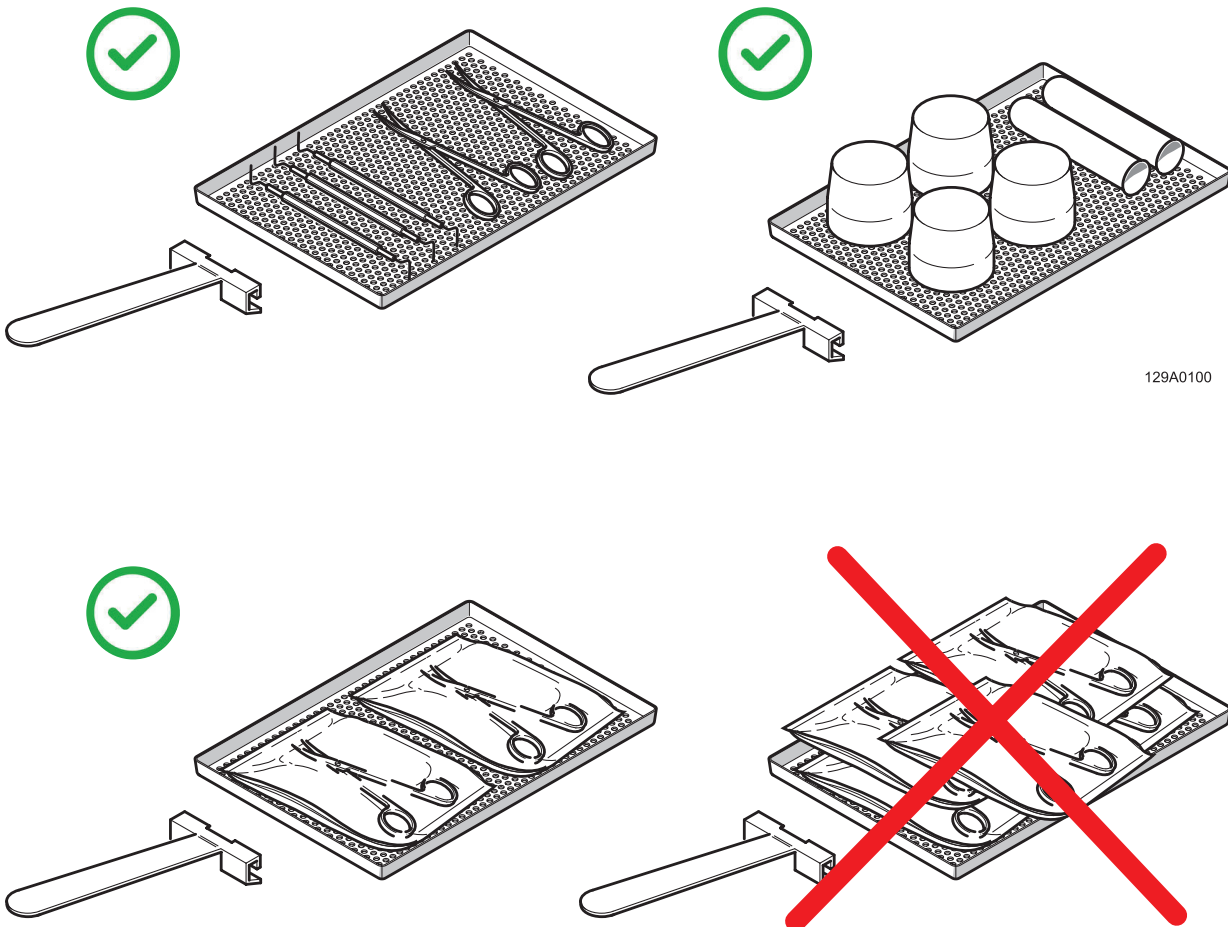

5.8 Program selection

Depending on the degree of sterilization to be obtained, the operator has various types of programs available, with a class B or class S sterilization cycle, described in the program table.

To select the programs, press the corresponding button on the operator panel.

PROGRAM TABLE

Program	Parameters			Cycle class	Process value		Cycle total time (with maximum load)	Type of Load	Maximum load*	
	Sterilization time	Pre-vacuum phases	Drying time		Temperature	Pressure			iClave 18	iClave 24
B UNIVERSAL	4'	3	10'	B	134 °C	2,03 bar	59'	Unwrapped solid and hollow loads	5 kg	7 kg
								Wrapped solid and hollow loads	3,5 kg	5 kg
								Double wrapped solid and hollow instruments	2 kg	3,5 kg
								Unwrapped porous instruments	1 kg	2 kg
								Wrapped porous instruments	1 kg	2 kg
								Double wrapped porous instruments	1 kg	2 kg
B PRION	18'30"	3	14'	B	134 °C	2,03 bar	78'	Unrapped solid and hollow instruments	5 kg	7 kg
								Wrapped solid and hollow loads	3,5 kg	5 kg
								Double wrapped solid and hollow instruments	2 kg	3,5 kg
								Unwrapped porous instruments	1 kg	2 kg
								Wrapped porous instruments	1 kg	2 kg
								Double wrapped porous instruments	1 kg	2 kg

Program	Parameters			Cycle class	Process values		Cycle total time (with maximum load)	Type of Load	Maximum load*	
	Sterilization time	Pre-vacuum phases	Drying time		Temperature	Pressure			iClave 18	iClave 24
B FAST**	3'30"	3	5'	B	134 °C	2,03 bar	29'	solids, hollows single wrapped and unwrapped instruments	0,5 kg	0,7 kg
B 121	20'30"	3	16'	B	121 °C	1,04 bar	82'	Unrapped solid and hollow instruments	5 kg	7 kg
								Wrapped solid and hollow loads	3,5 kg	5 kg
								Double wrapped solid and hollow instruments	2 kg	3,5 kg
								Unwrapped porous instruments	1 kg	2 kg
								Wrapped porous instruments	1 kg	2 kg
								Double wrapped porous instruments	1 kg	2 kg
S FAST***	3'30"	2	7'	S	134 °C	2,03 bar	32'	Unrapped solid instruments	1 kg	2 kg
B&D HELIX	3'30"	3	4'	/	134 °C	2,03 bar	/	Helix Test Pack or equivalent B&D Test Pack or equivalent		
VACUUM	/	/	/	/	<40°C	-0,86 bar	/	Empty Chamber		

*: load including the weight of the trays.

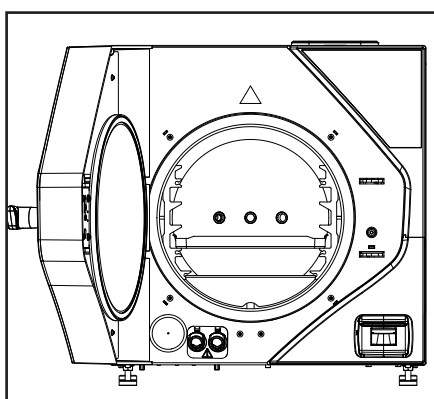

! **The **B Fast** program must be carried out using a single tray, to be placed in the second slot from the bottom.
 ***The **S Fast** doesn't guarantee class B sterilization.

After choosing the cycle, a new menu appears on the screen, containing various information. The central box summarizes the main data relating to the chosen cycle (pressure [1], temperature [2], maximum solid load [3] and maximum porous load [4]), while the three buttons located in the upper area allow you to modify the following sterilization process parameters:

- Changing the sterilization time;
- Changing the drying time;
- Cycle start delay.

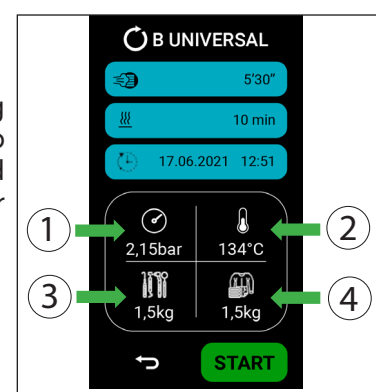

5.8.1 Sterilization time modification

Pressing the highlighted button you access to the sterilization time modification menu.

The minimum acceptable sterilization time is defined according to the cycle and the EN13060 standard (it will not be possible to have shorter sterilization times).

Pressing the **ENTER** button the data is confirmed and the screen return to the cycle start menu.

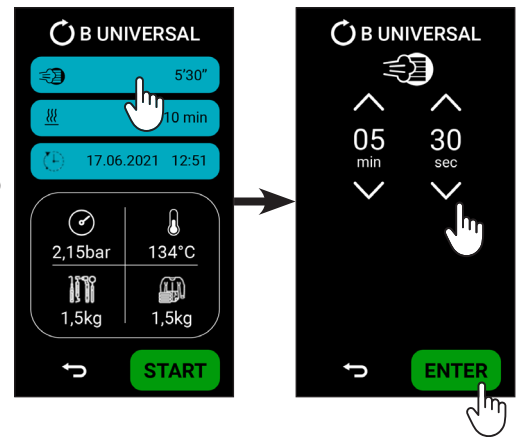

5.8.2 Drying time modification

Pressing the highlighted button you access to the drying time modification menu.

This function is used when the user must minimize the risk of wet load (due to the load itself).

The minimum acceptable drying time is defined according to the cycle and the EN13060 standard (it will not be possible to have shorter drying time).

Pressing the **ENTER** button the data is confirmed and the screen return to the cycle start menu.

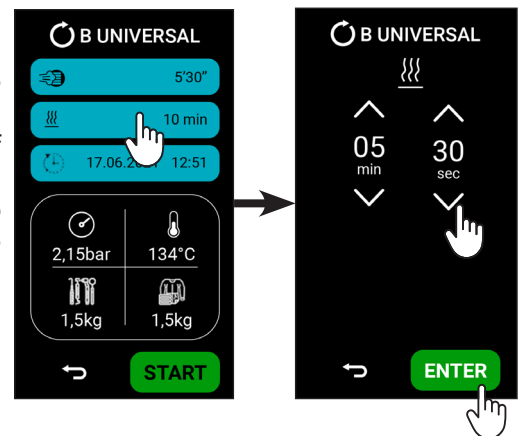

5.8.3 Cycle start delay

By pressing the highlighted button, you can set the cycle start date and time.

Pressing the **ENTER** button the data is confirmed and the screen return to the cycle start menu.

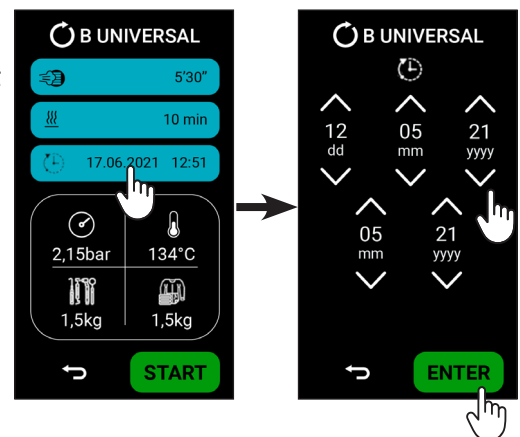

5.9 Running a cycle

Once the desired cycle has been chosen, by pressing the **START** button the device starts the cycle and a new page will appear, where you can monitor various information:

1. The current phase (pre-heating, pulsation, sterilization, drying);
2. The remaining time of completion of the cycle;
3. The pressure in the sterilization chamber;
4. The sterilization chamber temperature.
5. Cycle number;
6. The cycle info.

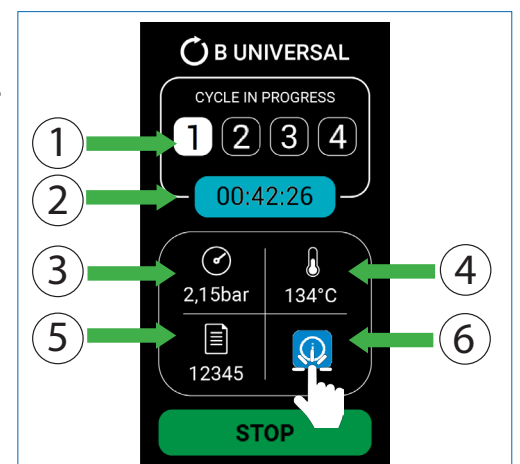

Throughout the cycle, you can access extra details by pressing the button **INFO**, which contains all the information related to the ongoing cycle.

The following information is displayed in the **CYCLE** column:

- the chamber temperature and pressure;
- the theoretical temperature;
- the temperature of the upper and lower band;
- the phase and subphase of the cycle;
- the conductivity of clean water;
- the status of the clean and used water tank;
- the ambient pressure.

The following information is displayed in the **SUMMARY** column:

- the time required for the sterilisation in the cycle;
- the time required for the drying in the cycle;
- the time for equilibration;
- the first pulsation's lowest temperature and pressure;
- the second pulsation's lowest temperature and pressure;
- the third pulsation's lowest temperature and pressure;
- the minimum sterilisation temperature and pressure;
- the maximum sterilisation temperature and pressure;
- the sterilization temperature change.

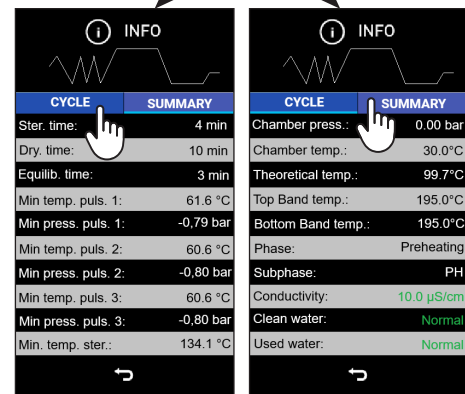
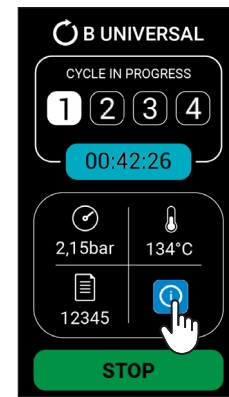

The cycle must be completed to see all parameters in the **SUMMARY** column.

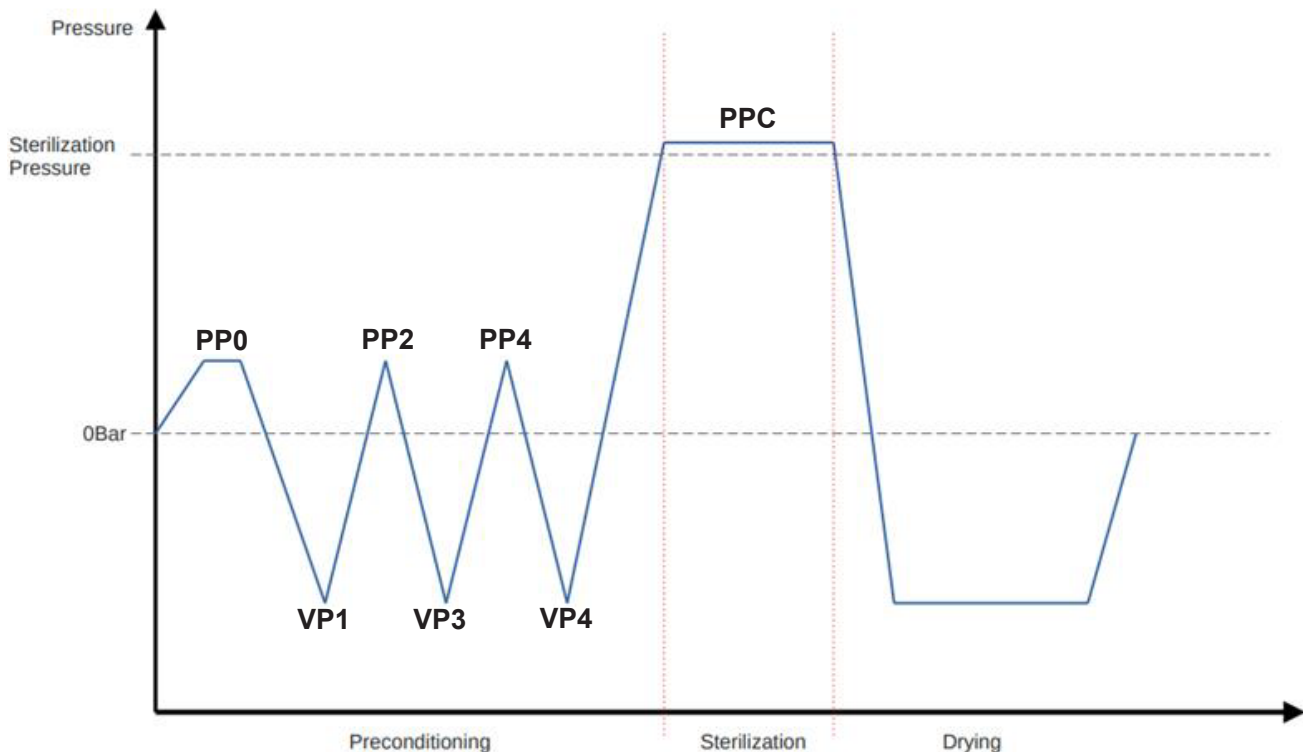

CLASS B CYCLES					
	Time (min)	Minimum pressure (bar)	Maximum pressure (bar)	Minimum temperature (°C)	Maximum temperature(°C)
PP0	/	+0,5 bar	+0,51 bar	/	/
VP1	/	-0,81 bar	-0,8 bar	/	/
PP2	/	+0,5 bar	+0,51 bar	/	/
VP3	/	-0,81 bar	-0,8 bar	/	/
PP4	/	+0,5 bar	+0,51 bar	/	/
VP4	/	-0,81 bar	-0,8 bar	/	/
PPC	4' ÷ 20'30"	+2,03 bar	+2,3 bar	134°C (121°C)*	137°C (124°C)*

*: only for B121 cycle.

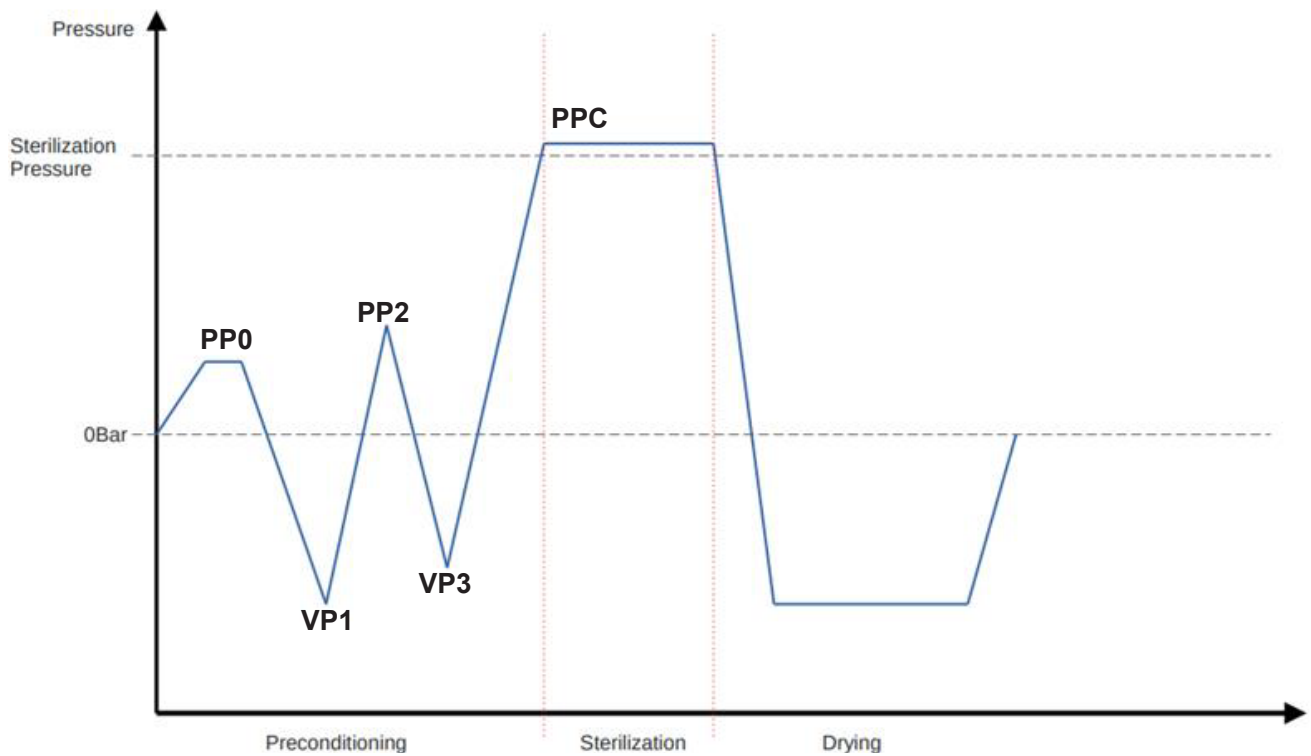

CLASS S CYCLES					
	Time (min)	Minimum pressure (bar)	Maximum pressure (bar)	Minimum temperature (°C)	Maximum temperature(°C)
PP0	/	+0,5 bar	+0,51 bar	/	/
VP1	/	-0,81 bar	-0,8 bar	/	/
PP2	/	+0,5 bar	+0,51 bar	/	/
VP3	/	-0,81 bar	-0,8 bar	/	/
PPC	3'30"	+2,03 bar	+2,3 bar	134°C	137°C

5.9.1 Pre-heating phase (1)

The pre-heating phase is the first phase of the sterilization cycle, this phase has the purpose of heating the device to reach the conditions suitable for the subsequent phases of the cycle.

It isn't an active phase and it isn't counted in the cycle time. The duration is however recorded in the report.

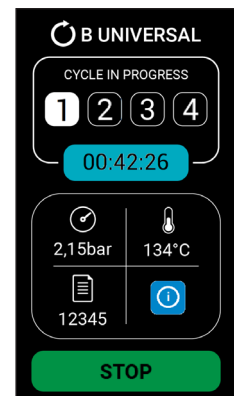

5.9.2 Pulses phase (2)

In this phase, with a sequence of vacuum pulses and positive pulses, the device removes the air from the chamber making it possible to carry out the sterilization phase.

The **STOP** during this phase leads to an interruption of the cycle according to EN13060.

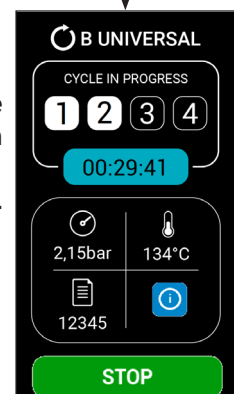

5.9.3 Sterilization phase (3)

During the sterilization phase, the temperature and pressure are kept stable for a predefined time in order to carry out the load sterilization process.

The **STOP** during this phase leads to an interruption of the cycle according to EN 13060.

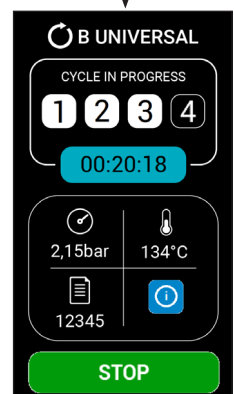

5.9.4 Drying phase (4)

The drying phase begins at the end of the sterilization phase, the duration of which complies with the predefined parameters. At the end of the drying phase it will be possible to unlock the door and remove the load. The **STOP** during this phase does not involve the interruption of the cycle as the sterilization phase is completed.



If starting with a cold machine, the drying time automatically increases by 4 minutes.

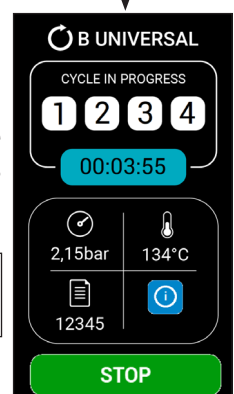

5.9.5 End of cycle

At the end of the cycle, the screen will change colour and will indicate whether the cycle has ended successfully (green) or unsuccessfully (red).

 Sterilized instruments and the sterilization chamber are very hot. Remove the trays very carefully using the special tool and without letting parts of the body come into contact with the hot parts.

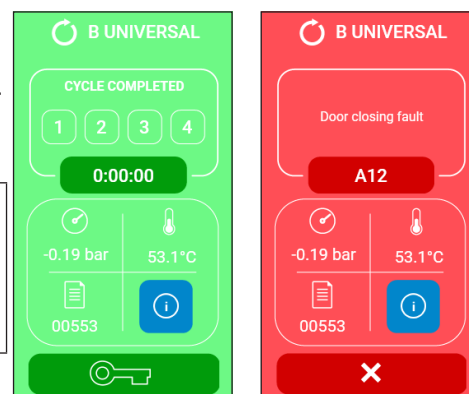

To unlock and open the door, press the key button below the screen and open the door (see par.5.2).

If the cycle is successfully completed, the load can be collected.

If a fault occurs during the cycle or an out of tolerance parameter is detected, the screen will turn a different color and the error code that caused the problem will appear (the door will remain locked). To view the error, press the error code that appears on the screen (example in the photo, button A50). After checking the error, press the X button to exit the cycle.

 If the cycle is unsuccessful, the devices are not sterile. Do not use the devices on patients.

In the presence of a printer (optional), the microprocessor sends the most significant data of the cycle to the printer to have a detailed report printed on paper with the certification value of the process carried out.

 Verification of proper storage and recording of each sterilization cycle is the responsibility of the user. It is the responsibility of the operator to ensure that the data is accurately stored and compliant with current regulations. It is recommended to regularly check the integrity and completeness of the records to ensure the traceability and compliance of the process.

The display now returns to the **HOME** menu.

Once the door is opened and the sterilized load removed, the sterilizer is ready to run a new program. The operator can prepare a new load and start a new sterilization cycle benefiting from a much faster heating time since the chamber is already hot.

 If the door is not opened and more than 30 minutes have passed since the end of the cycle, the device automatically switches into the standby mode (OFF state).

5.10 Interrupting the programme

If necessary, a running program can be aborted at any time by pressing the **STOP** button.

 In case of interruption of the cycle during the drying phase, the load is considered sterilized and it doesn't foresee a restart of the cycle. However, the load may be wet.

- After pressing the **STOP** button, the device proceeds to release the pressure before allowing the door to be opened for safety reasons. To unlock the door, press the key button.
- Remove the load very carefully and check for the presence of water inside the chamber (it is recommended to replace the bags if the load is wrapped).
- Before refilling the chamber, carefully dry the inside of the sterilization chamber and wait 10 minutes to allow the water to evaporate and completely drain.

 If the cycle is unsuccessful, the devices are not sterile. Do not use the devices on patients.

5.11 Topping up with demineralized water and draining contaminated water

The sterilizer is equipped with two 5-liter tanks: a main tank for demineralized water and a recovery tank for the water returned from the sterilization cycle.

The hydraulic circuit does not allow the reuse of the steam produced during the sterilization cycle, which is collected in the recovery tank and must be periodically drained.

The normal operating cycle therefore involves gradual emptying of the demineralized water tank and filling of the recovery tank.

5.11.1 Topping up the demineralized water tank

The average water consumption for each sterilization cycle is 650 cc, which means that a full tank allows about 8 cycles.

When the i20 information is activated (see the paragraph 6.2 "Information List") this indicates an insufficient water level in the loading tank.

Top up with demineralised water until you hear an acoustic signal (Fig.1) and a message appears on the display that the tank is full (Fig.2).

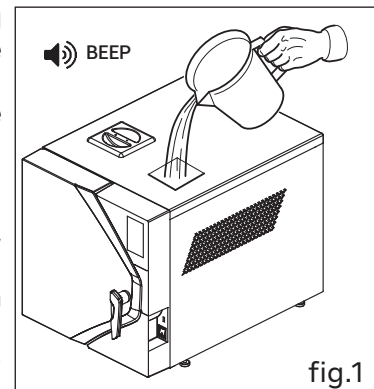

fig.1

! If you fill in too much water (even after the acoustic signal), the excess water will be discharged through the 'OVERFLOW CLEAN' connection located at the rear of the device (see Fig. 3).

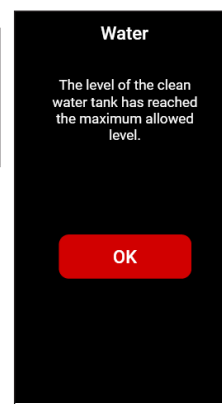

fig.2

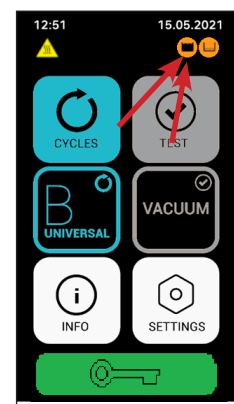

fig.4

5.11.2 Draining the used water recovery tank

If the symbol (Fig.4) is displayed, it indicates that the used water tank contains too much water.

Drain the tank by proceeding as follows:

1. Place a recovery container with a capacity of at least 6 liters;
2. Insert the drain hose into the grey hose connection on the front of the device (Fig. 5);
3. Wait for the tank to drain completely;
4. Remove the drain hose from the barb fitting.

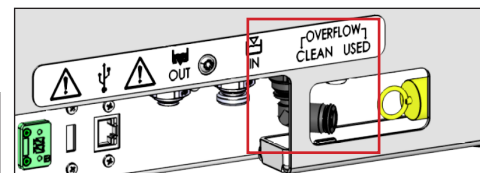

fig.3

! The water in the used water tank should be considered as biologically contaminated, therefore appropriate precautions should be taken if the tank is emptied. Used water must be disposed of in accordance with local or national regulations.

i The demineralized water tank can also be drained in the same way, if necessary, connecting the tube to the attachment quickly and positioning the selector on clean water.

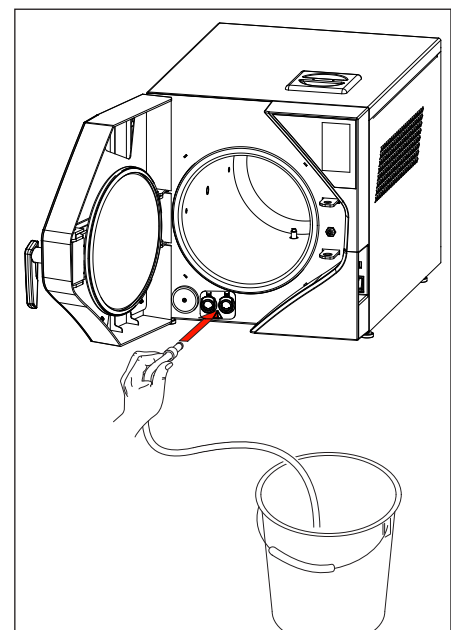



fig.5

5.11.3 Checking the water quality

To prevent accidental use of poor quality water, the device is equipped with an automatic water quality control system that measures its conductivity. The control system is part of the initial diagnostic tests and comes into operation automatically when the machine is switched on, provided that the device is at room temperature and with a full demineralized water tank.

At the end of the diagnostics, if the measured conductivity value is higher than 15 $\mu\text{S}/\text{cm}$, the notice I23 appears (see par. 6.2 "Information list").

The water conductivity value can be viewed in the INFO menu. The color of the value may vary depending on the level: **GREEN** if it is $<15 \mu\text{S}/\text{cm}$, **ORANGE** if it is between 15 and 50 $\mu\text{S}/\text{cm}$, **RED** if it is $>50 \mu\text{S}/\text{cm}$.

	The negative result of this check doesn't block the operation of the sterilizer; however, it is recommended to replace the demineralized water found to be of non-ideal quality, with a better quality one.
---	---

The following table shows the recommended minimum parameters for the water to be used

Pollutants	Supply water	Condensed
evaporation residue	$\leq 10 \text{ mg/l}$	$\leq 1,0 \text{ mg/l}$
silicon oxide	$\leq 1 \text{ mg/l}$	$\leq 0,1 \text{ mg/l}$
iron	$\leq 0,2 \text{ mg/l}$	$\leq 0,1 \text{ mg/l}$
cadmium	$\leq 0,005 \text{ mg/l}$	$\leq 0,005 \text{ mg/l}$
lead	$\leq 0,05 \text{ mg/l}$	$\leq 0,05 \text{ mg/l}$
residues of heavy metals, excluding iron, cadmium and lead	$\leq 0,1 \text{ mg/l}$	$\leq 0,1 \text{ mg/l}$
chlorine	$\leq 2 \text{ mg/l}$	$\leq 0,1 \text{ mg/l}$
phosphates	$\leq 0,5 \text{ mg/l}$	$\leq 0,1 \text{ mg/l}$
Conductivity (at 20°C)	$\leq 15 \text{ uS/cm}$	$\leq 3 \text{ uS/cm}$
pH	from 5 to 7,5	from 5 to 7
appearance	Colourless, clean without sediment	Colourless, clean without sediment
hardness	$\leq 0,02 \text{ mmol/l}$	$\leq 0,02 \text{ mmol/l}$

5.12 Peripheral devices

5.12.1 Internal printer (optional)

The model equipped with an integrated thermal printer, doesn't require any additional installation operations for printing the sterilization cycle.

In correct storage conditions (absence of exposure to direct sunlight and environmental conditions within the limits set out in chapter 3.3), the maintenance time for printing on paper is 10 years.

5.12.2 External printer connection (optional)

The device can have an integrated printer (optional) but it is also designed for connection to an external printer, to which process data is sent to document and certify that sterilization has been completed.

The recommended printer model offered by NSK Dental Italy is coded Ref. **9900009**, it's a compact desktop printer that can be connected to the USB port located in the back or front side of the device.

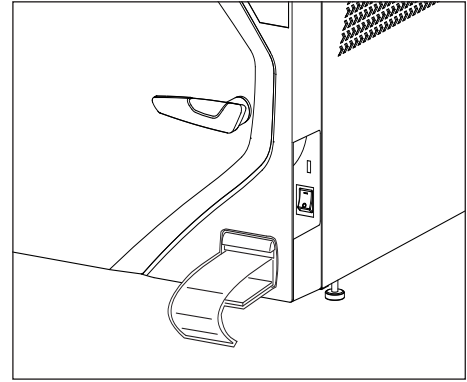

The report (Fig.1) is automatically printed at the end of the cycle, including the following information:

- User at the beginning of the cycle;
- User at the end of the cycle;
- date and time of the process;
- serial number of the cycle;
- cycle and parameters selected;
- type of process: sterilization or disinfection;
- start and end times of the sterilization phase;
- time of completion of the drying phase;
- Cycle start user;
- Cycle end user.

In the case of malfunction or interruption of the cycle, the printer will provide the message **CYCLE ABORTED - NOT STERILE** and will indicate the type of alarm encountered. At the end of the working day, turn the printer off.

Verification of proper storage and recording of each sterilization cycle is the responsibility of the user. It is the responsibility of the operator to ensure that the data is accurately stored and compliant with current regulations. It is recommended to regularly check the integrity and completeness of the records to ensure the traceability and compliance of the process.

The printer can provide labels in barcode form. The barcode contains the following information:

- model;
- serial number;
- 18-character identification number (serial number + cycle number + date);
- CODE 39 barcode;
- cycle name;
- cycle number;
- Cycle start user;
- Cycle end user.
- cycle date;
- expiry date (settable, see par.4.9.3.b);
- cycle outcome.

For printer management, refer to par. 4.8.3. "Printers Menu".

5.12.3 Archiving on a USB stick (optional)

The sterilizer can archive the sterilization reports on a USB stick as an alternative to printing on paper.

To connect, just use the supplied USB key or insert your own key into the USB socket on the front of the autoclave.

-----CLASS B-----

iClave 24
Ser. Num. GDN240001
Date: 12/04/24
Prog: BUInversa1
134.0 °C 4'00"
Cycle Num: 00436
START: 17:23:08
START OP: adg
END OP: adg
PREHEATING
Time: 00:00 (04:06)
Press: 0.014 bar
PULSATION
Time: 04:05 (00:44)
Press: 0.503 bar
VACUUM
Time: 05:19 (02:18)
Press: -0.800 bar
PULSATION
Time: 07:37 (02:08)
Press: 0.500 bar
VACUUM
Time: 09:45 (01:49)
Press: -0.800 bar
PULSATION
Time: 11:34 (01:33)
Press: 0.501 bar
VACUUM
Time: 13:07 (01:46)
Press: -0.800 bar
PULSATION
Time: 14:53 (02:34)
Press: 2.059 bar
STER.START
Time: 20:27 (04:00)
Press: 2.059 bar
Temperature: 134.1 °C
STER.END
Time: 24:27 (00:00)
Press: 2.144 bar
Temperature: 135.3 °C
DRYING START
Time: 24:27 (10:00)
DRYING END
Time: 34:27 (00:00)
END: 17:58:41

CYCLE COMPLETE

-----TEST-----

iClave 24
Ser. Num. GDN240001
Date: 05/12/2024
Prog: B&D
134.0 °C 3'30"
Cycle Num: 00276
START: 14:16:48
PREHEATING
Time: 00:00 (05:44)
Press: 0.009 bar
PULSATION
Time: 05:44 (01:45)
Press: 0.497 bar
VACUUM
Time: 07:59 (02:52)
Press: -0.800 bar
PULSATION
Time: 10:51 (03:41)
Press: 0.500 bar
VACUUM
Time: 14:32 (03:20)
Press: -0.800 bar
PULSATION
Time: 17:52 (02:48)
Press: 0.500 bar
VACUUM
Time: 20:40 (03:03)
Press: -0.800 bar
PULSATION
Time: 23:43 (07:40)
Press: 2.054 bar
STER.START
Time: 31:23 (03:30)
Press: 2.054 bar
Temperature: 134.1 °C
STER.END
Time: 34:53 (00:00)
Press: 2.116 bar
Temperature: 134.9 °C
DRYING START
Time: 34:53 (05:00)
DRYING END
Time: 39:53 (00:00)
END: 14:57:33

CYCLE COMPLETE

fig.1

HG2P24001700312041224*

iClave 24	S/N: GDN240001
st: 04/12/2024	exp: 03/01/2025
Cycle: B121	cycle n. 00312
Start OP: Admin	End OP: Admin
CYCLE COMPLETE	

fig.2

For archiving on a USB stick, refer to par. 4.8.5.
Do not connect devices not foreseen by the manufacturer.

 Verification of proper storage and recording of each sterilization cycle is the responsibility of the user. It is the responsibility of the operator to ensure that the data is accurately stored and compliant with current regulations. It is recommended to regularly check the integrity and completeness of the records to ensure the traceability and compliance of the process.

5.13 Web server

The DXPClave provides a web interface designed to make the following functions available via a common web browser on the local network:

- Real-time display of autoclave state;
- Download cycle reports (reports in PDF format);
- Set-up of the drying time;
- Downloads of cycle logs and system logs (if requested by Service for in-depth analysis).

5.13.1 How to open the Web Server page

- Connect the device via LAN via the rear Ethernet port;
- Access the INFO page of the device and view the IP address;

 We recommend using a static IP (contact your network administrator to find out which static IP to use or how to configure a fixed IP even when using a DHCP).

- Using a browser on a PC connected to the same network, access the page via the link <https://xxx.xxx.xxx> (where xxx.xxx.xxx is the IP address of the device on the INFO page) (Fig.6);

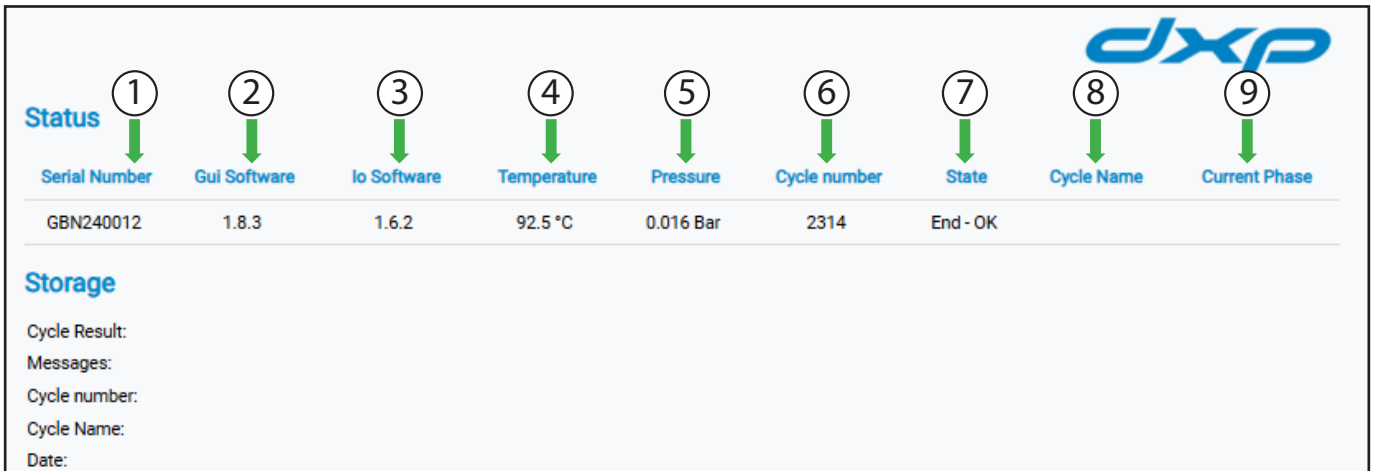

The screenshot displays the DXPClave web interface. At the top right is the 'DXP' logo. Below it, a 'Status' section contains nine items, each with a circled number and a green arrow pointing to its value:

1	2	3	4	5	6	7	8	9
Serial Number	Gui Software	Io Software	Temperature	Pressure	Cycle number	State	Cycle Name	Current Phase
GBN240012	1.8.3	1.6.2	92.5 °C	0.016 Bar	2314	End - OK		

Below the status section is a 'Storage' section with the following labels:

- Cycle Result:
- Messages:
- Cycle number:
- Cycle Name:
- Date:

 Files downloaded via the web server will be stored in the download directory of the browser. A preferred default directory can be specified, depending on the browser used.

5.13.2 Device state

The start page shows the general status of the device, the progress of the cycle and the main sterilisation parameters: temperature and pressure.

The device state data are as follows:

1. Device serial number
2. Version of the GUI software
3. Version of the IO software
4. Device chamber temperature
5. Device chamber pressure
6. Cycle number: number of the last cycle being processed
7. Device state (wait, cycle):
 - Wait: the device is waiting for a new cycle/test;
 - Cycle: the device is running a cycle/test;
 - END-OK: the device is completing the cycle/test and printing the report;
8. Cycle name: name of the test being conducted.
9. Current step: Name of the test step being currently running.

5.13.3 Download Data

With this function, data can be downloaded from the device and stored on the PC.

 During the execution of a cycle, it is not possible to download data. However, it is always possible to monitor the progress of the cycle and display temperature and pressure values in real time.

At the end of the cycle, the screen display allows you to view the result or download the report.

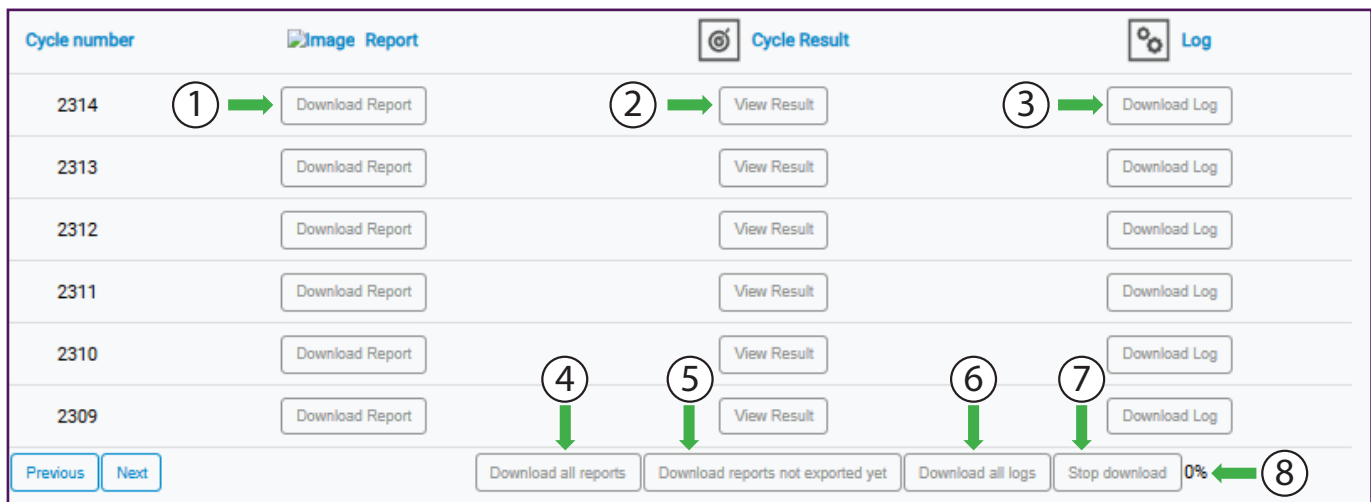

Cycle number	Image Report	Cycle Result	Log
2314	① → Download Report	② → View Result	③ → Download Log
2313	Download Report	View Result	Download Log
2312	Download Report	View Result	Download Log
2311	Download Report	View Result	Download Log
2310	Download Report	View Result	Download Log
2309	Download Report	View Result	Download Log

Previous Next
 ④ ↓ Download all reports
⑤ ↓ Download reports not exported yet
⑥ ↓ Download all logs
⑦ ↓ Stop download
0% ← ⑧

1. Download Report: By pressing the button, the device generates the report in PDF and downloads it to the download directory of the browser;
2. Result view: By pressing the button, the result of the cycle is shown at the top of the table, with the following entries:
 - Cycle Result: shows the outcome of the cycle execution;
 - Cycle Number: shows the number of the cycle executed;
 - Cycle name: shows the type of cycle executed;
 - Date of execution of the cycle.
3. Download log: By pressing the button, the log file will be downloaded (this type of file can only be used by the Service);
4. Download all reports: allows you to download all reports of the cycles performed;
5. Download reports not exported yet: allows you to download cycle reports that have not been exported yet;
6. Download all logs: allows downloading of cycle logs;
7. Stop Download: allows you to stop the current download process;
8. Download completion percentage.

5.13.4 How to set drying times

Dry time

B Prion (min) min ENTER

B Universal (min) min ENTER

B Fast (min) min ENTER

B 121 (min) min ENTER

S Fast (min) min ENTER

Select drying configuration:

0.sys ▼ Download Log

In this menu, you can set a longer drying time than the default one.



The minimum acceptable drying time is defined according to the cycle and compliant with the EN13060 standard (lower drying times will not be possible). The maximum time that can be set is 60 minutes.

To synchronise the time with the autoclave display, press the "ENTER" button next to the changed value.

5.14 Cybersecurity

This sterilizer has been designed and manufactured by NSK Dental Italy with the aim of removing, as far as possible, the impairment of performance or the risks associated with possible negative interactions between the device and the IT environment in which it operates, even if the medical device does not patient data is managed or saved, but only cycle reports.

To check the current firmware version use the info menu.

To prevent unauthorized use NSK Dental Italy has applied an intrinsically safe design which includes:

- End-to-end (TLS) encrypted data communications are used to keep communications with NSK Cloud confidential.
- Digital signatures are used to preserve integrity. Highly sensitive data, such as firmware updates, are accepted by authenticated end-points.
- Data flows in only one direction from the Ethernet port, the security context must be mutually authenticated, and cryptographic mechanisms, including encryption and signature verification, must be bi-directional.
- Corrections or firmware updates from NSK Dental Italy will be available promptly if needed and should be applied as soon as available. Systematic procedures will be in place for authorized users to download and install updates from NSK Dental Italy once a patch or new firmware is available.
- Full support will be available for users, in case of requests regarding device cybersecurity please write to servicesterilization@nsk-italy.it.

Then, to mitigate the risk of cybersecurity threats:

- the IT network where the device is installed and connected must be appropriate for this medical device (for example, the use of configurations may include end point protections such as anti-malware, firewall/firewall rules, whitelisting, security event parameters, logging parameters, physical security detection).
- Only the Ethernet port can be used to communicate with NSK Cloud.
- allow the use of the device only to suitable and adequately authorized personnel
- users must be careful not to spread their pins to enter the technical menu.

6. Alarms

6.1 Generality

When the device is switched on and during each sterilization cycle, the characteristic parameters of the various phases of the cycle are constantly monitored, together with the proper functioning and acceptable condition of all the components.

Any anomaly or fault is immediately indicated on the display through warning messages and alarm codes, together with an acoustic signal.

The following paragraphs show the possible information, notification and alarm messages in the table:

INFORMATION: the information will appear in case of incorrect use or in case of maintenance requested by the operator. These messages normally allow the cycle to start but require certain actions by the operator.

NOTIFICATIONS: warnings will appear in case of small malfunctions of the device; this type of malfunction does not cause the sterilization cycle to be interrupted. The cycle will continue until completion but at the end of the cycle it will be necessary to evaluate / solve the problem.

ALARMS: the alarms will appear in case of machine malfunctions that affect the sterilization cycle and lead to "Sterilization process failed" according to EN 13060:2014+A1:2018. These malfunctions require the immediate interruption of the process and the procedure for resetting the device. No further cycles can be performed until the cause of the fault is resolved..

The tables show:

- in the first column from the left the encoding of the message;
- in the second column the message shown on the display;
- in the third column the cause of the message;
- in the fourth column the solution to the problem, which in some cases can be solved by the operator, in others technical assistance is required.

	Instruments and sterilization chamber are very hot. Carry out the operations indicated without letting the parts of the body come into contact with hot surfaces.
--	--

6.2 Informations list

NR.	DISPLAY MESSAGE	CAUSE	SOLUTION
i01	Replace the bacteriological filter	The bacteriological filter has performed more than 500 cycles.	Replace the bacteriological filter and reset the dedicated counter.
i02	Replace door gasket	The door gasket has performed more than 1000 cycles.	Replace the door gasket and reset the dedicated counter.
i03	Carry out periodic inspection	A year has passed since installation date or more than 1000 cycles have been completed without any maintenance by technical support.	Require a complete check-up by a qualified technical service; contact technical maintenance.
i10	Close the door	Door not closed properly.	Check that the door is closed properly.
i20	Fill the tank	Insufficient water level in the clean water tank.	Fill the clean water tank.
i21	Clean water tank full	The level of the clean water tank has reached the maximum allowed level.	Stop filling the clean water tank.

i22	Used water tank full	The used water tank is full.	Empty the used water tank.
i23	Check clean water quality	Conductivity of clean water higher than 15 $\mu\text{S}/\text{cm}$, therefore too high.	Replace or fill the clean water tank with demineralized water.
i24	Bad clean water quality	Conductivity of clean water higher than 50 $\mu\text{S}/\text{cm}$, which could damage the device.	Drain and fill the clean water tank with demineralized water.
i30	Wait for cooling	Chamber temperature too high, Vacuum test not possible.	Turn off the device and leave the door open to cool the chamber.
i50	Cycle interrupted	The cycle was manually interrupted by the operator. Sterilization is not completed.	Dry the chamber, if wet, and restart the cycle. If it persists, contact technical assistance.

6.3 Notification list

NR.	DISPLAY MESSAGE	CAUSE	SOLUTION
N04	Replace the bacteriological filter	Clogged bacteriological filter.	Replace the bacteriological filter and reset the dedicated counter.
N05	Clean the drain filter	Clogged drain filter.	Clean or replace the filter under the metal plate at the bottom of the chamber.
N31	Clean the door gasket	Vacuum test failed. Possible leak in the door gasket.	Clean the door gasket and repeat the test. If it persists, contact technical assistance.
N32	Vacuum test failed: try again	The expected vacuum value was not reached within the set time.	Dry the chamber, if wet, and restart the cycle. If it persists, contact technical assistance.
N40	Pre-heating phase too long	Slow heating of the room.	Run the cycle with less load. If the problem persists, contact the technical assistance. Check the mains voltage.
N61	Reduce load	The minimum pressure value has not been reached within the set time.	Reduce the load to make drying easier.
N70	Faulty conductivity meter	Faulty or defective conductivity meter.	Contact technical assistance.

6.4 Alarms list

NR.	DISPLAY MESSAGE	CAUSE	SOLUTION
A11	Door closing fault	Failure of the door closing system sensors during the cycle. Sterilization not completed.	Contact technical assistance.
A12	Door closing fault	Failure in the door closing system sensors during drying. Sterilization completed.	Dry the load and use it immediately. Contact technical assistance.

A51	Vacuum phase too long; reduce the load	The expected vacuum value has not been reached within the set time.	Run a cycle with less load. If it persists, contact technical assistance.
A52	Clean the demineralized water filter	The pulse did not reach the value within the set time.	Empty the tank and clean the water filler filter. If it persists, contact technical assistance.
A53	Clean the door gasket	Cycle parameters misaligned. Air in the chamber.	Check the door gasket. Clean the gasket. If it persists, contact technical assistance.
A54	Clean the door gasket	Sterilization parameters too low. Temperature or pressure below the sterilization band. Sterilization not completed.	Check the door seal. If necessary, carry out a Vacuum Test. If it persists, contact technical assistance.
A55	Sterilization parameters too high	Temperature or pressure higher than the sterilization band. Sterilization not completed.	Contact technical assistance.
A56	Sterilization time too short.	Sterilization time too short. Sterilization is not performed.	Restart the cycle. If it persists, contact technical assistance.
A57	Equilibration time too long	Equilibration time too long. Sterilization is not performed.	Try to reduce the load and restart the cycle. If it persists, contact technical assistance.
A70	Black out: check the power supply	Blackout during the cycle. Sterilization not completed.	Check the electrical outlet. Dry the chamber and restart the cycle.
A71	Faulty chamber temperature sensor	Faulty or defective chamber temperature sensor.	Contact technical assistance.
A72	Defective pressure sensor	Faulty or defective pressure sensor.	Contact technical assistance.
A73	Defective upper band heater temperature sensor	Faulty or defective upper band heater temperature sensor.	Contact technical assistance.
A74	Defective lower band heater temperature sensor	Faulty or defective lower band heater temperature sensor.	Contact technical assistance.
A75	Pressure too high.	The pressure has reached too high values.	Contact technical assistance.
A76	Communication error.	Communication lost between the IO and GUI boards. Sterilization is not performed.	Turn off the autoclave and contact technical assistance.
A77	Internal communication problem	Communication problem with internal peripherals. Sterilization not performed.	Turn off the autoclave and contact technical assistance.
A78	Report memory anomaly	Cycle report memory anomaly.	Restart the device. If the problem persists, contact technical assistance.

7. Maintenance

7.1 Ordinary maintenance

	<p>Maintenance of the device must be carried out by suitably trained personnel, who have read and understood all the procedures and information given in this instruction manual, particularly in chapter 2 "Safety information".</p> <p>Always wear sterilized disposable latex gloves.</p>
---	--

To ensure maximum life and reliability of the device, it is recommended to perfect the cleaning and washing techniques of the instrumentation.

One of the main causes of premature wear of the sterilizer is given by residues on instruments that are not perfectly clean, with consequent formation of stains, encrustations and progressive obstructions of the filters, of the solenoid valves and of the hydraulic circuit.

The following table shows the routine maintenance that the operator or maintenance technician must perform regularly. It indicates the frequency of the maintenance and describes the type of operation to perform.

PERIODIC MAINTENANCE TABLE

Frequency	Type of operation	Operation procedure
Daily	Manual cleaning of the sterilization chamber. This should be done when the chamber is cold.	Cleaning to be done manually using a cloth moistened with demineralized water
Daily	Manual cleaning of the rubber gasket on the door. This should be done when the chamber is cold.	Cleaning to be done manually using a cloth moistened with demineralized water
Monthly or every 100 cycles	H2O filters cleaning (chamber and tank)	See paragraph 7.1.1 and 7.1.2.
Every 5 days of use or during a shutdown equal to or greater than 2 days	Tanks cleaning	Empty both tanks containing inlet and outlet water as described in paragraph 5.9.2. Rinse the tank with clean water to remove any deposits present around the filters and on the bottom. Wipe with a dry cloth inside and clean thoroughly. Do not use cleaning products or detergents inside the tank.
Every 6 months or every 500 cycles	Replacement of the bacteriological filter (code 021008)	See paragraph 7.1.2

7.1.1 Demineralized water filter replacement and cleaning

To clean or replace the demineralized water filter, open the tank cup and empty the clean water tank. When the tank is empty, remove the filter from its housing. Clean or replace the filter and re-insert it in its seat, taking care to insert it completely (use your thumb to push the filter as far as it will go).

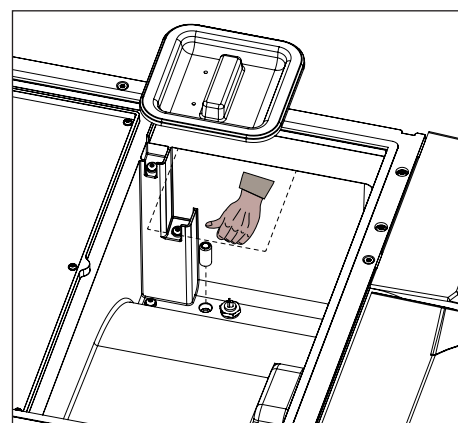

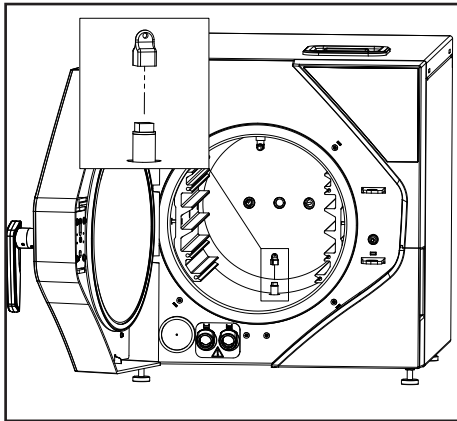

7.1.2 H2O chamber filter clean and replacement

To clean or replace the H2O filter in the chamber, it must be opened the hatch (unlocking it with the appropriate command on the screen) e unscrewing the filter at the bottom using the key supplied in the autoclave accessories kit.



Pay attention: possible hot surfaces.

7.1.3 Replacing the bacteriological filter



Replace the bacteriological filter with the device switched off.

Unscrew the bacteriological filter and replace it with a new one. Install the filter in its housing, taking care to ensure that it is fully screwed in.

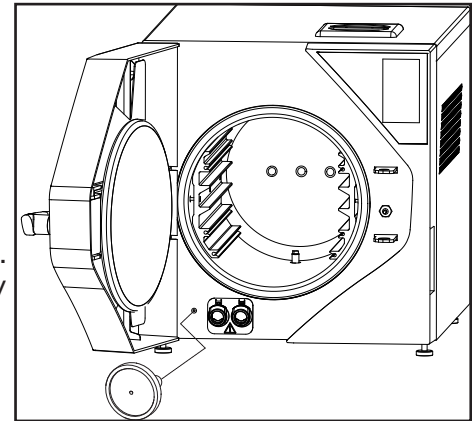

7.2 Scheduled maintenance

The following table indicates the scheduled maintenance operations to be carried out on the device by qualified and authorized personnel at the customer's premises, with the relative deadlines.

Pos	Check/activity	Responsible	Frequenze
1	Door adjustment		1 Year / 1.000 cycles
	- Gasket replacement	Maintainer / Technician	1 Year / 1.000 cycles
	- Disk-door clearance check	Maintainer / Technician	1 Year / 1.000 cycles
	- Lubrification	Maintainer / Technician	1 Year / 1.000 cycles
	- Component wear check	Maintainer / Technician	1 Year / 1.000 cycles
	- Closing pin replacement (if necessary)	Technician	2 Years / 2.000 cycles
2	Calibration	Maintainer / Technician	1 Year
3	Filter cleaning / replacement		1 Year / 1.000 cycles
	- Chamber cylindrical filter replacement	Operator	1 Year / 1.000 cycles
	- Clean water tank filter replacement	Operator	1 Year / 1.000 cycles
4	Pump feature check	Technician	1 Year / 1.000 cycles
5	Tanks cleaning	Maintainer / Technician	1 Year / 1.000 cycles
6	Radiator cleaning	Maintainer / Technician	1 Year / 1.000 cycles
7	Non-return valve replacement	Technician	2 Years / 2.000 cycles
8	Micropump replacement	Technician	2 Years / 2.000 cycles
9	Electric closing piston check / lubricate	Maintainer / Technician	2 Years / 2.000 cycles
10	Radiator outlet brass filter inspection / cleaning	Maintainer / Technician	2 Years / 2.000 cycles
11	Vacuum Pump Maintenance	Technician	2 Years / 2.000 cycles

NOTE: refer to the legislation and instructions for each individual country.

7.3 Periodic validation / requalification of the sterilization process

The sterilizer purchased complies with the applicable requirements of the safety standards in force, and the parameters set by the manufacturer are designed to ensure the sterility of the load in the conditions indicated in the manual.

To ensure process safety over time, it is necessary to check, periodically (1 year), the process

parameters (pressure and temperature), making sure that they remain within the limits set by the European reference standards EN 17665. and EN 556. The requalification of the performance of the sterilizer falls under the responsibility of the user of the product.

The requalification of the process (as well as extraordinary maintenance) must be carried out by the person identified as a "Technician" who corresponds to qualified and authorized personnel who carry out the operations at the NSK Dental Italy company, if the sterilizer must be returned or collected for repairs to be carried out in the laboratory or in the factory, please remember to accompany the sterilizer with a photocopy of the sales invoice and in case of return of the appropriate RMA authorization which must always be requested in advance before sending the device to the customer office care of NSK Dental Italy.

7.4 Fuses replacement



The replacement of the fuses must be carried out by the technician, who must have read and understood all the procedures and information contained in this instruction manual, in particular in chapter 2 "Safety information".

To replace the fuses, switch off the device and disconnect the power cable.

Unscrew the protection covers of the fuses and replace them with fuses with characteristics equivalent to those provided in the original equipment (see par. 3.8 Technical Data).

7.5 Useful life of the device

The average life of the sterilizer in service is 10 years. For normal use, the device is expected to be used and maintained following the instructions provided by NSK Dental Italy.

7.6 Hot and cold spot inside the chamber

The highlighted points in the photo show the areas within the chamber with the highest and lowest temperatures on average during normal operation.

The red dot is the maximum temperature and the blue dot is the minimum temperature.

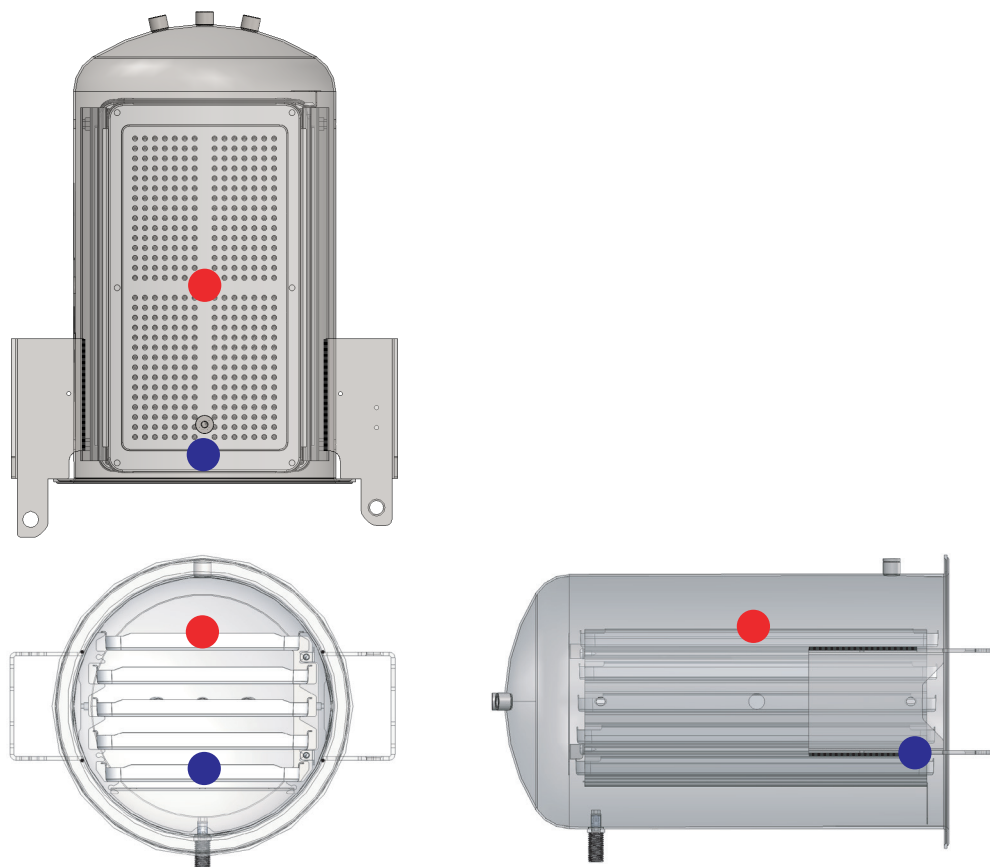

8. Disposal

The disposal of this device, as an electrical and electronic device, must be carried out separately from household waste by delivering it to your local collection / recycling center.



Packaging must be disposed of in accordance with local regulations applicable to the following materials:

- Outer box: carton;
- Sponge: expanded polyethylene;
- Pallet: wood.

Technical specifications may be modified without prior notice.
Pictures, description, quoting, dimension and technical data in this catalogue have to be considered as purely indicative.



NSK Dental Italy S.r.l. www.nsk-italy.it
Via dell'Agricoltura, 21 - 36016 Thiene (VI) Italy

NAKANISHI INC. www.nsk-dental.com
700 Shimohinata, Kanuma, Tochigi 322-8666, Japan



0051

REF	92412B0100	iClave 24 No Printer
REF	92412B0100P	iClave 24 Printer
REF	91812B0100	iClave 18 No Printer
REF	91812B0100P	iClave 18 Printer

